

SUPEROFFER
2023

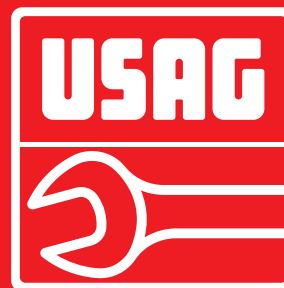

EN

New combination wrench 285 X

XTRA GRIP



Perfect on new hexagon,
effective on damaged bolt.

63/2023

valid till 31/03/2024

Index by item

New item

0			280 LTSTX/S8	Page 37	454	Page 56	519/280HG	Page 22	519 RS6/4NMM	Page 7	889 TRE	Page 66
001 RV	Page 29	280 TK/SE6	Page 34	458 E/B9	Page 56	519/280HGTS	Page 22	519 RS6/4NV	Page 5	889 TS	Page 67	
001 TRV	Page 29	280 TQ	Page 33	458 S20	Page 56	519/280T	Page 22	519 RS6/4V	Page 5	889 UB	Page 67	
002 JMA	Page 24	280 T/SE7	Page 34	468 M	Page 73	519/285A1	Page 22	519 RS7/3V	Page 4	890 K	Page 69	
002 JMP	Page 25	280 TTS/SE6	Page 34	495 MAA	Page 20	519/285B2	Page 22	519 RS7/5V	Page 5	900		
002 JTMA	Page 24	280 TTX/SE8	Page 34	495 MB	Page 20	519/285KA1	Page 22	519 RS8/3MM	Page 7	910 E1 1"	Page 79	
007/1V	Page 26	280 XLTS/S9	Page 37	495 MC	Page 20	519/294	Page 22	519 RS8/3V	Page 4	913 PC2 1/2"	Page 80	
007 FLV	Page 27	282 S10	Page 62	495 PA	Page 21	519/322H	Page 22	519 RSANV	Page 5	920 AN1	Page 80	
007 MCV	Page 27	285 DS8	Page 43	495 PM	Page 21	519/322STX	Page 22	519 RSAV	Page 5	921 A4	Page 80	
007 MLV	Page 59	285 DS12	Page 43	500			519/324H	Page 22	600			
007 MV	Page 59	285 J/DS7	Page 46	516 AC1	Page 14	519/324TX	Page 22	601 1/2" J22	Page 50	921 B1	Page 81	
007 PLV	Page 27	285 J/DS12	Page 46	516 AC2	Page 14	519/366	Page 22	601 1/4-1/2" J82	Page 51	922 B1	Page 81	
007 RV	Page 28	285 KA/DS8	Page 44	516 AC3	Page 14	519/382F	Page 22	601 1/4-1/2" J100	Page 51	922 B2	Page 81	
007 SV	Page 28	285 KA/DS12	Page 44	516 AC4	Page 14	519/613AEA	Page 22	601 1/4-1/2" JTX16	Page 50	922 BL1	Page 81	
007 TV	Page 28	285 KB/DS7	Page 45	516 AC5	Page 14	519/613BEA	Page 22	601 1/4" J34	Page 50	922 BP1	Page 81	
007 TXV	Page 26	285 KB/DS12	Page 45	516 AC6	Page 14	519/613CEA	Page 22	606 1/2" EA	Page 48	928 AC1 1/2"	Page 78	
007 V	Page 26	285 KF/DS8	Page 45	516 AC7	Page 14	519/990A1	Page 22	606 1/4" EA	Page 48	928 D1 3/4"	Page 78	
074 A	Page 59	285 KF/SE5	Page 45	516 AC8	Page 14	519 ACT1	Page 15	606 1/4" SK	Page 47	929 PC1 1/2"	Page 76	
085 EX/SE3	Page 38	285 P/SE5	Page 43	516 AC9	Page 14	519 ACT2	Page 15	608 1/4" EAK	Page 49	929 PC1/C12	Page 77	
091 D/SH5	Page 32	285 SE26	Page 43	516 AC10	Page 14	519 ACT3	Page 15	609 1/4" EB	Page 47	939 C1	Page 80	
091 SH5	Page 32	285 X/B8	Page 42	516 SA/C1	Page 16	519 ACT4	Page 15	610 1/4" EFK	Page 47	942 PC3 1/2"	Page 76	
091 SH8	Page 32	285 X/SE12	Page 42	516 SA/C2	Page 16	519 ACT5	Page 15	612 3/4" B	Page 49	942 PC3/C7	Page 77	
100			294 AC	Page 41	516 SA/C3	Page 17	519 ACT6	Page 15	612 3/4" EB	Page 49	942 PD1 3/4"	Page 78
115 CL/SE2	Page 74	294 AD	Page 41	516 SA/C4	Page 17	519 ACT7	Page 15	640 A	Page 29	942 PEL2 1"	Page 79	
127 C/SE4	Page 39	294 AG	Page 41	516 SA/CA1	Page 16	519 ACT8	Page 15	641 T	Page 29	943 PC1 1/2"	Page 76	
127 C/SE4S	Page 39	300			516 SA/CA2	Page 16	519 ACT9	Page 15	646/5LM183	Page 25	943 PC1/C12	Page 77
127 N/SE4	Page 39	322 SH7	Page 32	516 SA/CA3	Page 17	519 ACT10	Page 15	646/5LV	Page 29	943 PC2 1/2"	Page 78	
127 N/SE4S	Page 39	322 SH10	Page 32	516 SA/CA4	Page 17	519 ACT11	Page 15	664 B/S7	Page 36	988 D/S3	Page 63	
135 B	Page 40	324 SH5	Page 31	519 SE6MM	Page 13	519 ACT12	Page 15	664 S25	Page 36	988 E/S10	Page 63	
150 AX/SE3	Page 38	324 SH8	Page 31	519 SE6V	Page 13	519 ACT13	Page 15	687 1/2" C16	Page 82	988 G/S12	Page 63	
155 AX	Page 38	324 SH12	Page 31	519 SE6NV	Page 13	519 ACT14	Page 15	688 3/4" MD6	Page 82	988 LA/S14	Page 63	
163	Page 59	324 STX/S7	Page 31	516 SPC1	Page 18	519 M 091A	Page 23	692 J32	Page 36	988 MA/S19	Page 63	
174 CX	Page 40	324 XP/B16	Page 30	516 SPC2	Page 18	519 M 127N	Page 23	692 J49	Page 36	988 MA/S25	Page 63	
186 C	Page 40	333 K/SB10	Page 33	516 SPCN1	Page 18	519 M 150AX	Page 23	692 J100	Page 37	995 A	Page 57	
200			333 K/SH8	Page 33	516 SPCN2	Page 18	519 M 276	Page 23	800			
200 S	Page 60	367 SE6	Page 61	516 ST5V	Page 8	519 M 280HG	Page 23	810 N	Page 54	810 N	Page 54	
207 D	Page 58	376	Page 61	516 ST6MA	Page 11	519 M 280HGTS	Page 23	810 SA	Page 53	811 LB	Page 52	
207 E	Page 58	382	Page 61	516 ST6MM	Page 11	519 M 280N1	Page 23	811 LBE	Page 52	811 NE	Page 54	
210 C	Page 60	382 F	Page 61	516 ST6NMA	Page 11	519 M 280T	Page 23	811 SE	Page 53	811 N	Page 54	
211 A	Page 60	391	Page 74	516 ST6NMM	Page 11	519 M 280TK	Page 23	814 A	Page 55	814 A	Page 55	
211 B	Page 60	400			516 ST6NPA	Page 10	519 M 285A1	Page 23	824 A	Page 54	828 X4	Page 55
218 N	Page 60	400 P	Page 74	516 ST6NPM	Page 10	519 M 285A2	Page 23	831 A	Page 55	831 A	Page 55	
235 1/2" MB/C10	Page 83	421 M	Page 69	516 ST6NPP	Page 10	519 M 285KA	Page 23	870 C	Page 73	871 C	Page 73	
235 1/2" M/C16	Page 82	421 P	Page 69	516 ST6NV	Page 8	519 M 285KB	Page 23	871 D	Page 73	871 D	Page 73	
235 3/4" M/C8	Page 82	426 B/S5	Page 74	516 ST6PA	Page 10	519 M 294B	Page 23	884 C/S6	Page 71	884 C/S6	Page 71	
236 K	Page 83	426 C/S4	Page 74	516 ST6PM	Page 10	519 M 324H	Page 23	885 F	Page 71	889 GR	Page 65	
236 KE	Page 83	426 D/S4	Page 74	516 ST6V	Page 8	519 M 324STX	Page 23	889 IL	Page 64	889 IL	Page 64	
236 KE/C22	Page 83	443 N	Page 72	516 ST7NV	Page 8	519 M 382F	Page 23	889 LTE	Page 66	889 RL	Page 64	
237 1/2" AK	Page 49	443 NC	Page 72	516 ST7V	Page 8	519 M 613AEA	Page 23	889 RP	Page 66	889 RP	Page 66	
237 1/4" AK	Page 49	445 B	Page 75	516 ST8V	Page 9	519 M 613BEA	Page 23	889 RT	Page 65	889 RT	Page 65	
252 N/SR8	Page 46	446 DA/SE6	Page 72	516 STC4V	Page 9	519 M 613CEA	Page 23	889 TL	Page 67	889 TL	Page 67	
263/S16	Page 73	446 DT/S2	Page 73	516 STS6NV	Page 9	519 M 990A5MD	Page 23	889 TM	Page 67	889 TM	Page 67	
270 C/C3	Page 71	446 RT	Page 75	516 STXL6MM	Page 12	519 RBO7/3V	Page 5	889 TR	Page 67	889 TR	Page 67	
272 DS	Page 70	446 S28	Page 72	516 STXL6NMM	Page 12	519 RBU6/3V	Page 5	5000				
276 CE/SE8	Page 46	447 T	Page 68	516 STXL6NV	Page 9	519 RS6/3MA	Page 6	5006 EF2	Page 19	5006 EF6	Page 19	
280 HAP/SE6	Page 35	449 IDA	Page 75	516 STXL6V	Page 9	519 RS6/3MM	Page 6					
280 HATX/SE6	Page 35	449 TA	Page 75	516 SU2V	Page 9	519 RS6/3NMA	Page 6					
280 HG/SE6	Page 35	449 TB	Page 75	516 SUXLV	Page 9	519 RS6/3NMM	Page 6					
280 HGTS/SE6	Page 35	449 TC	Page 75	519/127N	Page 22	519 RS6/3NV	Page 4					
280 LTS/S9	Page 37	449 TC	Page 75	519/150AX	Page 22	519 RS6/3V	Page 4					
		451 N/S4	Page 56	519/276	Page 22	519 RS6/4MM	Page 7					

DISCOVER THE NEWS 2023



280 TQ

Hexagon keys and bits
Page 33



285 X

Wrenches
Page 41



811 LB

Controlled tightening
Page 52



Lighting
Page 64



Roller cabinets
Page 4



Workshop furniture
Page 16

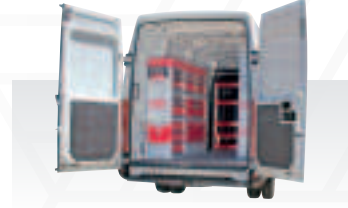

Van fitting storage
Page 19



Assortments
Page 20



Maintenance suitcase
Page 24



Portable storage
Page 26



Screwdrivers
Page 30



Pliers
Page 38

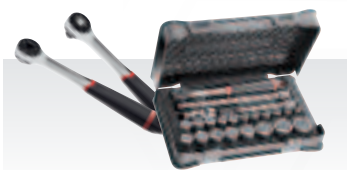

Ratchets and sockets
Page 47



Pullers
Page 56



Rivet pliers
Page 57



Electrician scissors
Page 58



Electrotechnics
Page 59

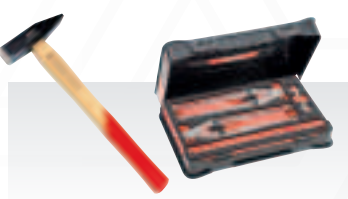

Maintenance
Page 60



Automotive
Page 68



Air tools and accessories
Page 76



LOOK FOR
ICONIC PRODUCT:
the tools that make the difference!



519 RACING ROLLER CABINET YOUR PREMIUM AND PROFESSIONAL WORKSHOP.



**TWO WHEELS
WITH BRAKE**

A new wider worktop
With double handle

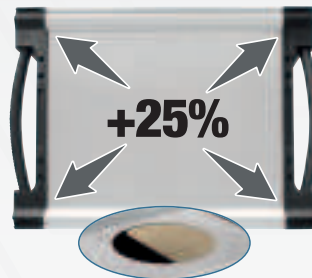

Double layer
Above: 2 mm aluminium plate.
Below: 15 mm wooden piece.



Rubber bumpers on
structure and drawers



New aluminium ergonomic handles
with selective opening



Save your time

All USAG roller cabinets are immediately ready for use, because they are supplied with the wheels already mounted on the structure



900 kg

**8
DRAWERS**
**3
MODULES**

79 kg | mm | 814
1005
575



900 kg

**7
DRAWERS**
**3
MODULES**

77 kg | mm | 814
1005
575



900 kg

**6
DRAWERS** | **3
MODULES**

75 kg | mm | 814
1005
575

519 RS6/3V

U05190506

RAL 3020

RACING roller cabinet (empty)

519 RS8/3V

U05190508

RAL 3020

RACING roller cabinet (empty)

- Inside dimensions:
6 drawers 570x420x60 mm
2 drawers 570x420x130 mm

519 RS7/3V

U05190507

RAL 3020

RACING roller cabinet (empty)

- Inside dimensions:
5 drawers 570x420x60 mm
1 drawer 570x420x130 mm
1 drawer 570x420x270 mm

519 RS6/3NV

U05190516

RAL 9005

RACING roller cabinet (empty)

- Inside dimensions:
4 drawers 570x420x60 mm
1 drawer 570x420x130 mm
1 drawer 570x420x270 mm



89 kg | mm | 1004
1005
575

519 RS6/4V
U05190546

RAL 3020

RACING roller cabinet (empty)

519 RS6/4NV
U05190566

RAL 9005

RACING roller cabinet (empty)

- Inside dimensions:
4 drawers 760x420x60 mm
1 drawer 760x420x130 mm
1 drawer 760x420x270 mm



106 kg | mm | 1194
1035
575

519 RS7/5V
U05190556

RAL 3020

RACING roller cabinet (empty)

- Inside dimensions:
5 drawers 950x420x60 mm
1 drawer 950x420x130 mm
1 drawer 950x420x270 mm



106 kg | mm | 1194
1035
575

519 RB07/3V
U05190097

RAL 3020

RACING roller cabinet with side door (empty)

- Inside dimensions:
5 drawers 570x420x60 mm
1 drawer 570x420x130 mm
1 drawer 570x420x200 mm
- Side cabinet: 380x400x720 mm



1100 kg

6 DRAWERS | 3 MODULES | 128 kg | mm | 1.212
1000
670

519 RBU6/3V
U05190098

RAL 3020

RAL 9005

RACING mobile workbench (empty)

- Inside dimensions of the drawers:
3 drawers 570 x420x60 mm
2 drawers 570 x420x130 mm
1 drawer 570 x420x200 mm
- Side compartment: 380x704x524 mm

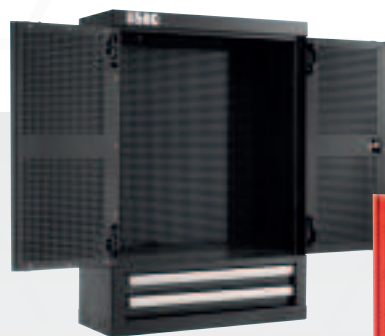

2 DRAWERS

45 kg | mm | 720
1.000
280



519 RSAV
U05190400

RAL 3020

RAL 9005

Empty tool cabinet - 2 drawers

519 RSANV
U05190401

RAL 9005

Empty tool cabinet - 2 drawers

- Internal perforated panels
- Doors opening at 180°
- Fully opened drawers
- Telescopic ball-bearing slides
- Drawers with anodized Aluminium handle



Roller cabinets

CAN'T FIND
Go now to



6
DRAWERS

3
MODULES



6
DRAWERS

3
MODULES

156
PIECES

519 RS6/3MM
U05190628

RAL
3020



519 RS6/3NMM
U05191628

RAL
9005

RACING roller cabinet with assortment for MAINTENANCE 495 MB - 4 drawers

155
PIECES

519 RS6/3MA
U05190627

RAL
3020



519 RS6/3NMA
U05191627

RAL
9005

RACING roller cabinet with AUTOMOTIVE assortment 495 MAA - 3 drawers

MAINTENANCE ASSORTMENT

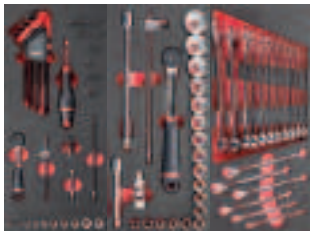

519 M 613AEA 519 M 613CEA 519 M 285A1

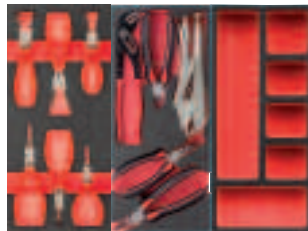

519 M 127C 519 M 150AX 519 MSK6



519 M 324H 519 M 324STX 519 MSK6+
692 J32



519 M 990A5B 519 M 382 519 MSK6

DESCRIPTION	ITEM	PCS.
Hexagonal sockets, ratchet (237 A 1/4"), accessories 1/4" and bits	519 M 613AEA	46
Hexagonal sockets, ratchet (237 A 1/2") and accessories 1/2"	519 M 613CEA	23
Combination wrenches (6-7-8-9-10-11-12-13-14-15-16-17-18-19-21-22-24 mm)	519 M 285A1	17
Pliers for circlips internal and external 15÷25 and 19÷60	519 M 127C	6
Universal pliers, adjustable pliers, cutting nippers, extra-long nose pliers, lock-grip pliers	519 M 150AX	5
Screwdrivers for slot-head and PHILLIPS® screws	519 M 324H	7
Screwdrivers for TORX® Tamper Resistant screws (T10-T15-T20-T25-T30-T40)	519 M 324STX	8
Flat square file, half-round file, round file, square file, triangular file (bastard cut)	519 M 990A5B	5
Hammer for mechanics with graphite handle, mallet, pin punches, chisel and centre punch	519 M 382F	7
Assortment with bits and reversible ratchet	692 J32	32

AUTOMOTIVE ASSORTMENT

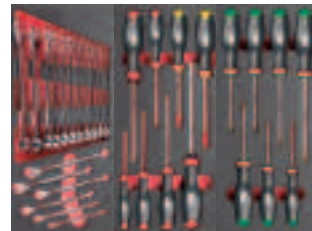

519 M 285A1 519 M 324H 519 M 324STX



519 M 613AEA 519 M 612CLA



519 M 276C

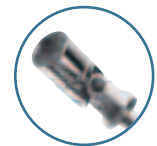

T-WRENCHES WITH JOINT
8-10-13-17 mm

DESCRIPTION	ITEM	PCS.
Hexagonal sockets, ratchet (237 A 1/4"), accessories 1/4" and bits	519 M 613AEA	46
Bihexagonal sockets, ratchet (237 A 1/2") and accessories 1/2"	519 M 612CLA	35
Combination wrenches (6-7-8-9-10-11-12-13-14-15-16-17-18-19-21-22-24 mm)	519 M 285A1	17
Screwdrivers for slot-head and PHILLIPS® screws	519 M 324H	7
Screwdrivers for TORX® Tamper Resistant screws	519 M 324STX	8
Pliers for circlips, combination pliers, long nose pliers, T-handle wrenches with hex sockets (8-10-13-17 mm), bits set with ratchet	519 M 276C	42

YOUR IDEAL ASSORTMENT?
Kitplanner-gb.usag.it and create it!



6
DRAWERS

4
MODULES



8
DRAWERS

3
MODULES

301
PIECES

519 RS6/4MM
U05190632

RAL
3020

301
PIECES

519 RS8/3MM
U05192632

RAL
3020

RACING roller cabinet with assortment
for **MAINTENANCE 495 MC - 4 drawers**

519 RS6/4NMM
U05191632

RAL
9005

RACING roller cabinet with assortment
for **MAINTENANCE 495 MC - 4 drawers**

MAINTENANCE ASSORTMENT

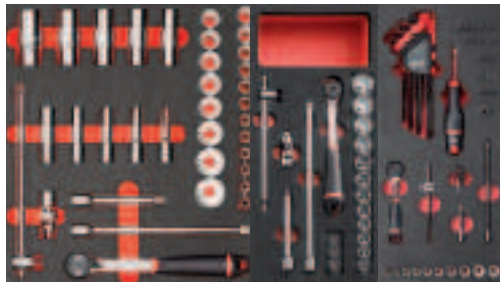

519 M 612CLA

519 M 613BEA

519 M 613AEA

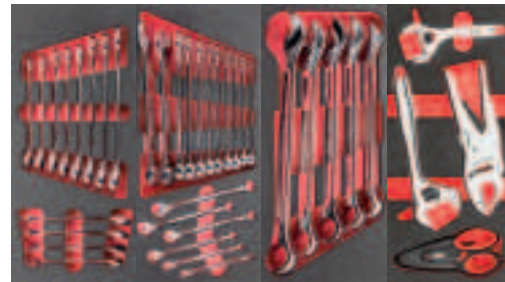

519 M 285KA

519 M 285A1

519 M 285A2

519 M 294B



519 M 324H

519 M 324STX

519 M 280HG

519 M 280N1



519 M 127C

519 M 150AX

519 M 382F

519 M 990A5MD

DESCRIPTION	ITEM	PCS.
Hexagonal sockets, ratchet (237 A 1/4"), accessories 1/4" and bits	519 M 613AEA	46
Hexagonal sockets, ratchet (237 A 3/8") and accessories 3/8"	519 M 613BEA	20
Bihexagonal sockets, ratchet (237 A 1/2") and accessories 1/2"	519 M 612CLA	35
Reversible ratchet combination wrenches 8-9-10-11-12-13-14-15-16-17-18-19 mm	519 M 285 KA	12
Combination wrenches (6-7-8-9-10-11-12-13-14-15-16-17-18-19-21-22-24 mm)	519 M 285A1	17
Combination wrenches 27-29-30-32-34 mm	519 M 285A2	5
Adjustable wrenches, lock-grip pliers and scissor	519 M 294B	4
Screwdrivers for slot-head and PHILLIPS® screws	519 M 324H	7

DESCRIPTION	ITEM	PCS.
Screwdrivers for TORX® Tamper Resistant screws (T10-T15-T20-T25-T30-T40)	519 M 324STX	8
Hexagon keys with handgrip (3-4-5-6-7-8-10 mm)	519 M 280HG	7
Set of keys for TORX® screws and assortment of bits with special shapes	519 M 280N1	117
Pliers for circlips internal and external 15÷25 and 19÷60	519 M 127C	6
Universal pliers, adjustable pliers, cutting nippers, extra-long nose pliers, lock-grip pliers	519 M 150AX	5
Flat square file, half-round file, round file, square file, triangular file (second cut)	519 M 990A5MD	5
Hammer for mechanics with graphite handle, mallet, pin punches, chisel and centre punch	519 M 382F	7

Do you want only the assortment? Go to page 20



516 START ROLLER CABINET MORE RESISTANT AND RELIABLE.



New worktop 460 x 560 mm
with 15 mm sides



High resistance 35 mm slides
with a load capacity up to 40 kg



New drawer handles in high resistant
ABS with selective opening



Save your time

All USAG roller cabinets are immediately ready for use, because they are supplied with the wheels already mounted on the structure.

<p>800 kg</p> <p>5 DRAWERS</p> <p>3 MODULES</p> <p>54 kg 779 mm 972 mm 515 mm</p>	<p>800 kg</p> <p>6 DRAWERS</p> <p>3 MODULES</p> <p>55 kg 779 mm 972 mm 515 mm</p>	<p>800 kg</p> <p>7 DRAWERS</p> <p>3 MODULES</p> <p>56 kg 779 mm 972 mm 515 mm</p>
--	--	--

516 ST5V

U05160105



START roller cabinet (empty)

- Inside dimensions:
2 drawers 570x420x60 mm
2 drawers 570x420x130 mm
1 drawer 570x420x270 mm

516 ST6V

U05160106



START roller cabinet (empty)

516 ST6NV

U05160116



START roller cabinet (empty)

- Inside dimensions:
3 drawers 570x420x60 mm
2 drawers 570x420x130 mm
1 drawer 570x420x200 mm

516 ST7V

U05160107



START roller cabinet (empty)

516 ST7NV

U05160117



START roller cabinet (empty)

- Inside dimensions:
5 drawers 570x420x60 mm
1 drawers 570x420x130 mm
1 drawer 570x420x200 mm



800 kg

8
DRAWERS

3
MODULES

58 kg | mm | 779
↑ 972
↘ 515

516 ST8V
U05160108

RAL
3020

START roller cabinet (empty)

- Inside dimensions:
6 drawers 570x420x60 mm
2 drawers 570x420x130 mm



800 kg

6
DRAWERS

4
MODULES

68 kg | mm | 969
↑ 972
↘ 515

516 STXL6V
U05160146

RAL
3020

START XL roller cabinet (empty)

516 STXL6NV
U05160156

RAL
9005

START XL roller cabinet (empty)

- Inside dimensions:
3 drawers 760x420x60 mm
2 drawers 760x420x130 mm
1 drawer 760x420x200 mm

Safety Lock System



800 kg



6
DRAWERS

3
MODULES

56 kg | mm | 779
↑ 972
↘ 515

516 STS6NV
U05160136

RAL
9005

START roller cabinet with Safety Lock System (empty)

- Inside dimensions:
3 drawers 570x420x60 mm
2 drawers 570x420x130 mm
1 drawer 570x420x200 mm

Double drawers

4
DRAWERS

3
MODULES



34 kg | mm | 779
↑ 467
↘ 515

516 STC4V
U05160104

RAL
3020

START drawer chest (empty)

- Inside dimensions:
3 drawers 570x420x60 mm
1 drawer 570x420x130 mm



200 kg

30 kg | mm | 779
↑ 972
↘ 515

2
DRAWERS

3
MODULES

3
SHELVES

**COMPATIBLE
WITH 516 START
ACCESSORIES**

516 SU2V
U05160002

RAL
3020

START utility chart - 2 drawers (empty)

- Work top in high resistant ABS with built-in 15 mm edges to prevent objects from falling during transport
- Shelves with edges to prevent objects from falling during transport and plastic cover
- Delivered dismounted
- Inside dimensions:
2 drawers 570x420x60 mm

Extra-large model

22 kg | mm | 969
↑ 972
↘ 515

3
SHELVES



300 kg

516 SUXLV
U05160003

RAL
3020

START XL utility chart

- Work top in high resistant ABS with built-in 15 mm edges to prevent objects from falling during transport
- Shelves with edges to prevent objects from falling during transport and plastic cover
- Delivered dismounted

Roller cabinets

CAN'T FIND
Go now to



6
DRAWERS

3
MODULES



6
DRAWERS

3
MODULES

157
PIECES

516 ST6PM
U05160630

RAL
3020

142
PIECES

516 ST6PA
U05160629

RAL
3020



516 ST6NPM
U05161630

RAL
9005



516 ST6NPA
U05161629

RAL
9005

START roller cabinet with AUTOMOTIVE assortment 495 PM - 4 drawers

START roller cabinet with AUTOMOTIVE assortment 495 PA - 2 drawers

MAINTENANCE ASSORTMENT



519/613AEA 519/613CEA 519 SK692V



519/285A1 519/150AX 519 SK692V

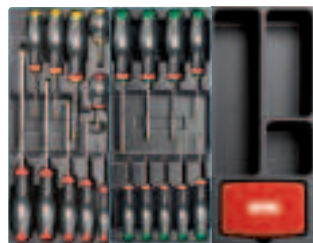

519/324H 519/324TX 519 SK692V + 692 J32



519 SK692V 519/990A1 519/382F

AUTOMOTIVE ASSORTMENT



519/613AEA 519/613CEA 519 SK692V + 692 J32



519/324H 519/285A1 519/150AX

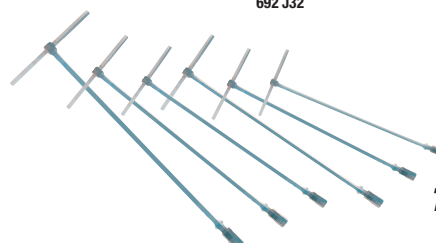

T-WRENCHES WITH
7-8-10-12-13-17 mm

DESCRIPTION	ITEM	PCS.
Hexagonal sockets, ratchet (237 A 1/4"), accessories 1/4" and bits	519/613AEA	42
Hexagonal sockets, ratchet (237 A 1/2") and accessories 1/2"	519/613CEA	22
Combination wrenches (6-7-8-9-10-11-12-13-14-15-16-17-18-19-22-24 mm) and angled keys (1,5-2-2,5-3-4-5-6-8-10 mm)	519/285A1	25
Universal pliers, adjustable pliers, cutting nippers, extra-long nose pliers, lock-grip pliers	519/150AX	5
Screwdrivers for slot-head and PHILLIPS® screws	519/324H	10
Screwdrivers for TORX® screws	519/324TX	9
Flat square file, half-round file, round file, triangular file (second cut)	519/990A1	4
Hammers, chisels and pin punches	519/382F	8
Assortment with bits and reversible ratchet	692 J32	32

DESCRIPTION	ITEM	PCS.
Hexagonal sockets, ratchet (237 A 1/4"), accessories 1/4" and bits	519/613AEA	42
Hexagonal sockets, ratchet (237 A 1/2") and accessories 1/2"	519/613CEA	22
Screwdrivers for slot-head and PHILLIPS® screws	519/324H	10
Combination wrenches (6-7-8-9-10-11-12-13-14-15-16-17-18-19-22-24 mm) and angled keys (1,5-2-2,5-3-4-5-6-8-10 mm)	519/285A1	25
Universal pliers, adjustable pliers, cutting nippers, extra-long nose pliers, lock-grip pliers	519/150AX	5
T-handle wrenches with jointed hexagonal socket (7-8-10-12-13-17 mm)	276 CE	6
Assortment with bits and reversible ratchet	692 J32	32

Do you want only the assortment? Go to page 21

YOUR IDEAL ASSORTMENT? Kitplanner-gb.usag.it and create it!



6
DRAWERS

3
MODULES



6
DRAWERS

3
MODULES

156
PIECES

516 ST6MM
U05160628

RAL
3020

155
PIECES

516 ST6MA
U05160627

RAL
3020



516 ST6NMM
U05161628

RAL
9005



516 ST6NMA
U05161627

RAL
9005

**START roller cabinet with assortment for
MAINTENANCE 495 MB - 4 drawers**

**START roller cabinet with AUTOMOTIVE
assortment 495 MAA - 3 drawers**

MAINTENANCE ASSORTMENT

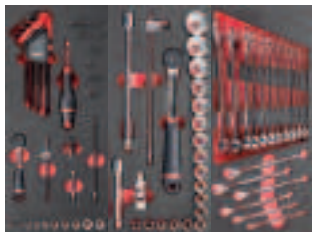

519 M 613AEA 519 M 613CEA 519 M 285A1

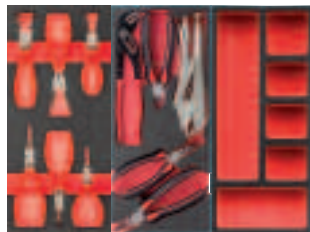

519 M 127C 519 M 150AX 519 MSK6



519 M 324H 519 M 324STX 519 MSK6+
692 J32



519 M 990A5MD 519 M 382 519 MSK6

AUTOMOTIVE ASSORTMENT

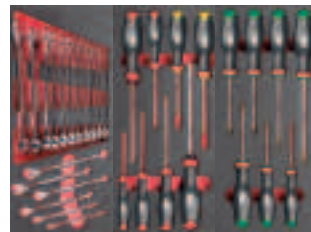

519 M 285A1 519 M 324H 519 M 324STX



519 M 613AEA 519 M 612CLA



519 M 276C



T-WRENCHES WITH
8-10-13-17 mm

DESCRIPTION	ITEM	PCS.
Hexagonal sockets, ratchet (237 A 1/4"), accessories 1/4" and bits	519 M 613AEA	46
Hexagonal sockets, ratchet (237 A 1/2") and accessories 1/2"	519 M 613CEA	23
Combination wrenches (6-7-8-9-10-11-12-13-14-15-16-17-18-19-21-22-24 mm)	519 M 285A1	17
Pliers for circlips internal and external 15÷25 and 19÷60	519 M 127C	6
Universal pliers, adjustable pliers, cutting nippers, extra-long nose pliers, lock-grip pliers	519 M 150AX	5
Screwdrivers for slot-head and PHILLIPS® screws	519 M 324H	7
Screwdrivers for TORX® Tamper Resistant screws	519 M 324STX	8
Flat square file, half-round file, round file, square file, triangular file (second cut)	519 M 990A5MD	5
Hammer for mechanics with graphite handle, mallet, pin punches, chisel and centre punch	519 M 382F	7
Assortment with bits and reversible ratchet	692 J32	32

DESCRIPTION	ITEM	PCS.
Hexagonal sockets, ratchet (237 A 1/4"), accessories 1/4" and bits	519 M 613AEA	46
Bihexagonal sockets, ratchet (237 A 1/2") and accessories 1/2"	519 M 612CLA	35
Combination wrenches (6-7-8-9-10-11-12-13-14-15-16-17-18-19-21-22-24 mm)	519 M 285A1	17
Screwdrivers for slot-head and PHILLIPS® screws	519 M 324H	7
Screwdrivers for TORX® Tamper Resistant screws	519 M 324STX	8
Pliers for circlips, combination pliers, long nose pliers, T-handle wrenches with hex sockets (8-10-13-17 mm), bits set with ratchet	519 M 276C	42

Do you want only the assortment? Go to page 20

Roller cabinets

CAN'T FIND
Go now to



6
DRAWERS

4
MODULES



6
DRAWERS

4
MODULES

301
PIECES

516 STXL6MM
U05160632

RAL
3020

START XL roller cabinet with assortment for MAINTENANCE 495 MC - 4 drawers



301
PIECES

516 STXL6NMM
U05161632

RAL
9005

START XL roller cabinet with assortment for MAINTENANCE 495 MC - 4 drawers



MAINTENANCE ASSORTMENT

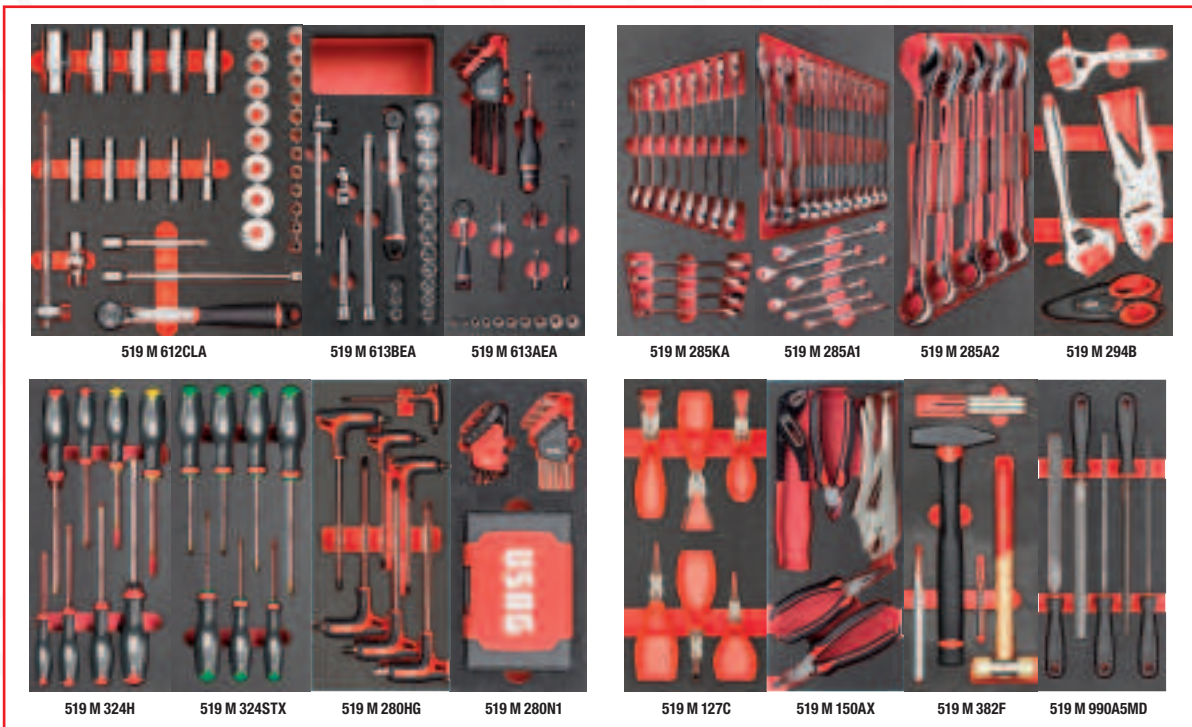

519 M 612CLA

519 M 613BEA

519 M 613AEA

519 M 285KA

519 M 285A1

519 M 285A2

519 M 294B

519 M 324H

519 M 324STX

519 M 280HG

519 M 280N1

519 M 127C

519 M 150AX

519 M 382F

519 M 990A5MD

DESCRIPTION

DESCRIPTION	ITEM	PCS.
Hexagonal sockets, ratchet (237 A 1/4"), accessories 1/4" and bits	519 M 613AEA	46
Hexagonal sockets, ratchet (237 A 3/8") and accessories 3/8"	519 M 613BEA	20
Bihexagonal sockets, ratchet (237 A 1/2") and accessories 1/2"	519 M 612CLA	35
Reversible ratchet combination wrenches 8-9-10-11-12-13-14-15-16-17-18-19 mm	519 M 285 KA	12
Combination wrenches (6-7-8-9-10-11-12-13-14-15-16-17-18-19-21-22-24 mm)	519 M 285A1	17
Combination wrenches 27-29-30-32-34 mm	519 M 285A2	5
Adjustable wrenches, lock-grip pliers and scissor	519 M 294B	4
Screwdrivers for slot-head and PHILLIPS® screws	519 M 324H	7

DESCRIPTION

DESCRIPTION	ITEM	PCS.
Screwdrivers for TORX® Tamper Resistant screws	519 M 324STX	8
Hexagon keys with handgrip (3-4-5-6-7-8-10 mm)	519 M 280HG	7
Set of keys for TORX® screws and assortment of bits with special shapes	519 M 280N1	117
Pliers for circlips internal and external 15÷25 and 19÷60	519 M 127C	6
Universal pliers, adjustable pliers, cutting nippers, extra-long nose pliers, lock-grip pliers	519 M 150AX	5
Flat square file, half-round file, round file, square file, triangular file (second cut)	519 M 990A5MD	5
Hammer for mechanics with graphite handle, mallet, pin punches, chisel and centre punch	519 M 382F	7

YOUR IDEAL ASSORTMENT? Kitplanner-gb.usag.it and create it!



50 kg | 750 mm | 900 mm | 500 mm

New

6
DRAWERS

3
MODULES

516 SE6V
U05160096

RAL 9006

START roller cabinet (empty)

516 SE6NV
U05160095

RAL 9005

START roller cabinet (empty)

- Inside dimensions:
4 drawers 570x420x60 mm
1 drawer 570x420x130 mm
1 drawer 570x420x200 mm



High resistance 35 mm slides with a load capacity up to 40 kg



Worktop in ABS with integrated handle



New

6
DRAWERS

296
PIECES

3
MODULES



516 SE6MM
U05160633

RAL 9006

516 SE6NMM
U05161633

RAL 9005

START roller cabinet with assortment for MAINTENANCE 495 MME - 3 drawers

MAINTENANCE ASSORTMENT



519 M 601



519 M 150



519 M 322H

519 M 322STX

519 M 280N1

DESCRIPTION	ITEM	PCS.
Adjustable plier, chisel, pin punch, hammer, scissor, assortment with bits, plier for circlips, universal plier, nose plier, cutting nipper, mallet	519 M 150	49
Set of keys for TORX® screws and assortment of bits with special shapes	519 M 280N1	117
Screwdrivers for slot-head and PHILLIPS® screws	519 M 322H	8

DESCRIPTION	ITEM	PCS.
Screwdrivers for TORX® Tamper Resistant screws/ T10-T15-T20-T25-T30-T40	519 M 322STX	6
Combination wrenches, sockets, ratchet and accessories	519 M 601	116

ACCESSORIES FOR 516 START AND 519



516 AC1
U05160301

Paper roll holder



516 AC2
U05160302

Bottle holder



516 AC3
U05160303

Document holder



516 AC4
U05160304

Waste holder



516 AC5
U05160305

Side cabinet with lock



516 AC6
U05160306

Foldable shelf



516 AC7
U05160307

Power tools holder



516 AC8
U05160308

Side power connection

- Multiple electric Schuko sockets with USB
- Cable length: 1,8 m.



516 AC9
U05160309

Wooden top

- Accessory dedicated only for the worktop of START 516 ST roller cabinets
- 15 mm thickness



COMPLETE YOUR ROLLER CABINET AND MAKE IT PERFECT

All the roller cabinets of the 516 START range could be completed with the new range of lateral accessories.

They are easy to be fixed, adding new features for different destinations of use. The new 516 START accessories range is compatible also with all the 519 RACING models and with the 516 START workshop furniture line.

RANGE RACING ROLLER CABINETS



519 ACT1

U05190301

Laptop holder



519 ACT2

U05190302

Bottle and paper roll holder



 **YouTube**



519 ACT3

U05190303

Drawers locking bar



519 ACT4

U05190304

Panel for documents and foam modules



519 ACT5

U05190305

Document holder



519 ACT6

U05190306

Wooden top M3 (775 mm)



519 ACT7

U05190307

Wooden top M4 (965 mm)



519 ACT8

U05190308

Wooden top M5 (1155 mm)



519 ACT9

U05190309

Wooden top for vice



519 ACT10

U05190310

Back hooks



519 ACT11

U05190311

Perforated panel with shelf

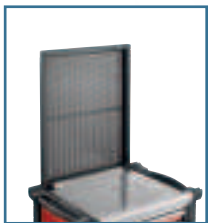

519 ACT12

U05190312

Double perforated panel



519 ACT13

U05190313

Perforated/flat panel with shelf



519 ACT14

U05190314

Triple shelf



CREATE THE IDEAL ROLLER CABINET FOR YOUR JOB.

The new worktop has an integrated system that allows to fix a new range of specific accessories.

Together with the use of standard side accessories you can turn your RACING into a real professional workstation.



YouTube



CHOOSE YOUR

Try it now: go to



Hooks and LED lamps included

**POSSIBILITY TO INVERT THE DOOR
OPENING DIRECTION**



Hooks, LED lamps and power strips included



516 SA/CA1
U05160235

135 kg | 1.450 mm | 2.000 mm | 650

Steel top
1.450 mm
516 AC/1

Workshop furniture - steel top

- Supplied with 30 hooks (kit 516 SA/K1)



516 SA/C1
U05160231

127 kg | 1.450 mm | 2.000 mm | 650

Wooden top
1.450 mm
516 SAL/1

Workshop furniture - wooden top

- Supplied with 30 hooks (kit 516 SA/K1)

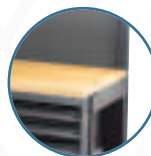

DESCRIPTION	ITEM	PCS.
Cabinet with 6 drawers	516 SA/1	1
Cabinet with 2 doors	516 SA/2	1
Pegboard	516 SA/5	6
Raising support	516 SA/11	2
LED lamp	516 SA/12	2
Metal shelf for LED lamp	516 SA/13	2
Fitting kit	516 SA/14	2
Kit of hooks for panels	516 SA/K1	1



516 SA/CA2
U05160236

198 kg | 1.950 mm | 2.000 mm | 650

Steel top
1.450 mm
516 AC/1

Workshop furniture - steel top

- Supplied with 30 hooks (kit 516 SA/K1)



516 SA/C2
U05160232

190 kg | 1.950 mm | 2.000 mm | 650

Wooden top
1.450 mm
516 SAL/1

Workshop furniture - wooden top

- Supplied with 30 hooks (kit 516 SA/K1)

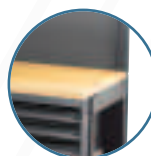

DESCRIPTION	ITEM	PCS.
Cabinet with 6 drawers	516 SA/1	1
Cabinet with 2 doors	516 SA/2	1
Cabinet with 1 door	516 SA/3	1
Top chest with tilting door	516 SA/4	2
Pegboard	516 SA/5	3
Pegboard with power strip	516 SA/6	1
Raising support	516 SA/11	3
LED lamp	516 SA/12	2
Fitting kit	516 SA/14	2
Kit of hooks for panels	516 SA/K1	1

IDEAL LAY-OUT

start516-gb.usag.it

**POSSIBILITY TO INVERT THE DOOR
OPENING DIRECTION**



STEEL

516 SA/CA3
U05160237

289 kg | mm ↔ 2.675
↓ 2.000
↙ 650

Steel top
2.175 mm
516 AC/2

Workshop furniture - steel top

- Supplied with 30 hooks (kit 516 SA/K1)

WOOD

516 SA/C3
U05160233

278 kg | mm ↔ 2.675
↓ 2.000
↙ 650

Wooden top
2.175 mm
516 SAL/2

Workshop furniture - wooden top

- Supplied with 30 hooks (kit 516 SA/K1)

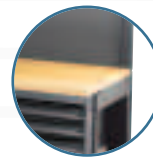

DESCRIPTION	ITEM	PCS.
Cabinet with 6 drawers	516 SA/1	1
Cabinet with 2 doors	516 SA/2	1
Cabinet with 1 door	516 SA/3	1
Top chest with tilting door	516 SA/4	3
Pegboard	516 SA/5	5
Pegboard with power strip	516 SA/6	1
Raising support	516 SA/11	3
LED lamp	516 SA/12	2
Fitting kit	516 SA/14	3
Kit of hooks for panels	516 SA/K1	1
START roller cabinet - 6 drawers (empty)	516 SA/16	1

**Hooks, LED lamps and
power strips included**

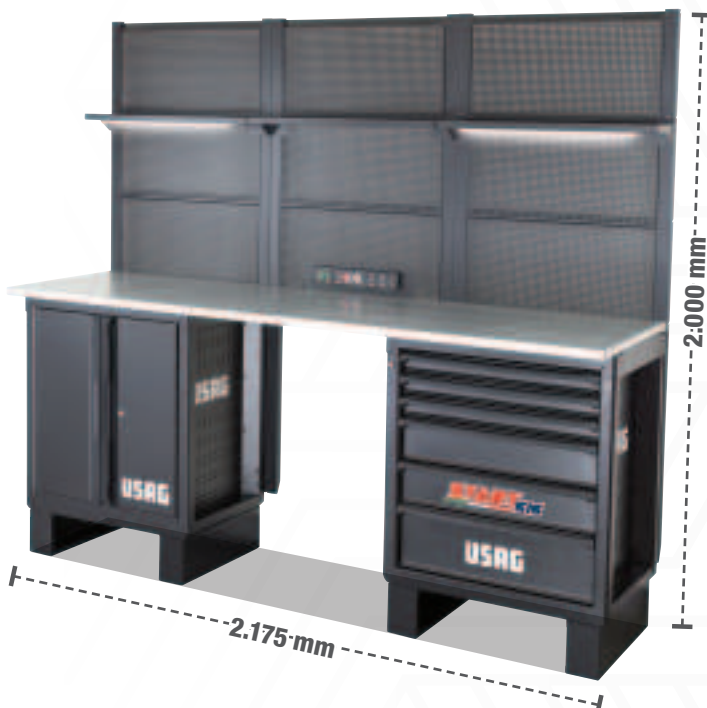

STEEL

516 SA/CA4
U05160238

160 kg | mm ↔ 2.175
↓ 2.000
↙ 650

Steel top
2.175 mm
516 AC/2

Workshop furniture - steel top

- Supplied with 30 hooks (kit 516 SA/K1)

WOOD

516 SA/C4
U05160234

147 kg | mm ↔ 2.175
↓ 2.000
↙ 650

Wooden top
2.175 mm
516 SAL/2

Workshop furniture - wooden top

- Supplied with 30 hooks (kit 516 SA/K1)

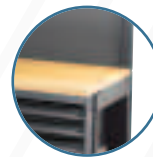

DESCRIPTION	ITEM	PCS.
Cabinet with 6 drawers	516 SA/1	1
Cabinet with 2 doors	516 SA/2	1
Pegboard	516 SA/5	8
Pegboard with power strip	516 SA/6	1
Raising support	516 SA/11	2
LED lamp	516 SA/12	2
Metal shelf for LED lamp	516 SA/13	3
Fitting kit	516 SA/14	3
Kit of hooks for panels	516 SA/K1	1

**Hooks, LED lamps and power
strips included**

Workbenches

1000 kg

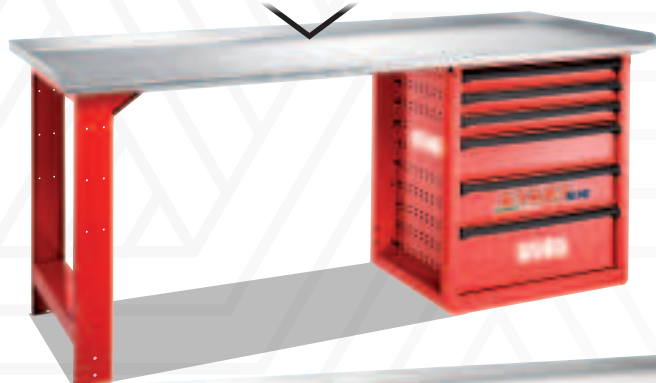

STEEL

6
DRAWERS

3
MODULES

102 kg | mm | 2.000
850
700

516 SPC2
U05160021

RAL
3020

START workbench with sheet steel top (empty)

- Inside dimensions:
3 drawers 570x420x60 mm
2 drawers 570x420x130 mm
1 drawer 570x420x200 mm

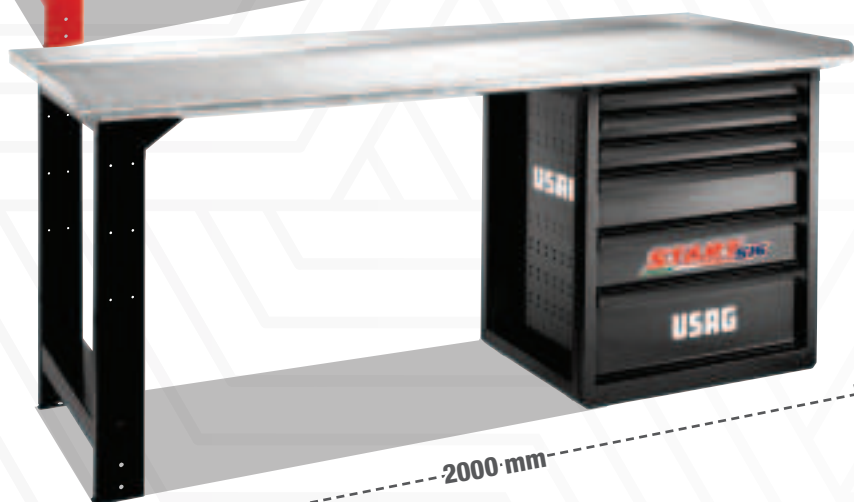

516 SPCN2
U05160023

RAL
9004

START workbench with sheet steel top (empty)

Galvanized sheet steel top

Anti-corrosion treated and with 37 mm anti-fall edges.

2000 mm

1000 kg

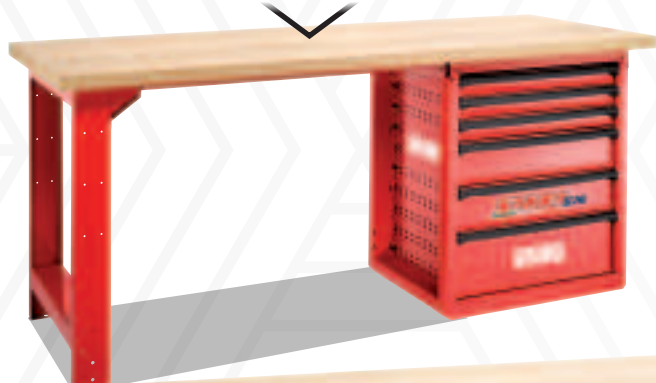

WOOD

6
DRAWERS

3
MODULES

115 kg | mm | 2.000
850
700

516 SPC1
U05160020

RAL
3020

START workbench with wooden top (empty)

- Inside dimensions:
3 drawers 570x420x60 mm
2 drawers 570x420x130 mm
1 drawer 570x420x200 mm



516 SPCN1
U05160022

RAL
9004

START workbench with wooden top (empty)

Multilayer beech-wood top

The thickness of 40 mm guarantees top resistance.

2000 mm

THE MODULAR SYSTEM FOR LAY-OUT OF COMMERCIAL VEHICLES

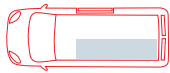

**LEFT
SIDE**



96 kg | mm | 1.238
1.146
375

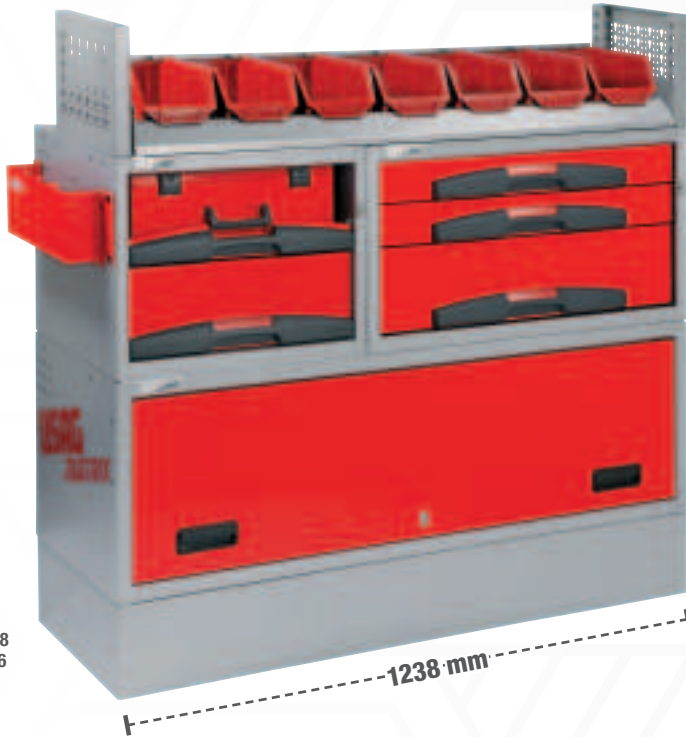

5006 EF2 U50060035

Composition:

DESCRIPTION	CODE	PCS.
Composition with boxes and drawers 5000 E5	U50000105	1
Composition with drawers 5000 CE3	U50000052	1
Base 5002 B3	U50020010	1
Bottle-holder 5002 SA5	U50020067	1
Uprights 5003 MF1	U50030052	1
Tray-holders 5003 A2/7	U50030074	1
Fixing bar 5002 S5	U50020048	2

Frame the QR code to check the compatible vehicle models

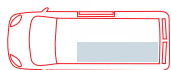

**LEFT
SIDE**



43 kg | mm | 990
1.014
375



5006 EF6 U50060040

Composition:

DESCRIPTION	CODE	PCS.
Composition for plastic cases 5000 AD2	U50000004	1
Composition with drawers 5000 C3	U50000042	1
Base 5002 B2N	U50020009	1
Shelf 5002 R2	U50020031	1
Bottle-holder 5002 SA5	U50020067	1
Fixing bar 5002 S5	U50020048	1

Frame the QR code to check the compatible vehicle models



BI-COLOUR FOAM MODULES

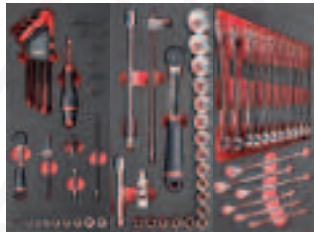

519 M 613AEA 519 M 613CEA 519 M 285A1



519 M 127C 519 M 150AX 519 MSK6



519 M 324H 519 M 324STX 519 MSK6+692 J32



519 M 990A5MD 519 M 382 519 MSK6

495 MB
U04950628

156
PIECES



Assortment for MAINTENANCE - 4 drawers

DESCRIPTION	ITEM	PCS.
Hexagonal sockets, ratchet (237 A 1/4"), accessories 1/4" and bits	519 M 613AEA	46
Hexagonal sockets, ratchet (237 A 1/2") and accessories 1/2"	519 M 613CEA	23
Combination wrenches (6-7-8-9-10-11-12-13-14-15-16-17-18-19-21-22-24 mm)	519 M 285A1	17
Pliers for circlips internal and external 15÷25 and 19÷60	519 M 127C	6
Universal pliers, adjustable pliers, cutting nippers, extra-long nose pliers, lock-grip pliers	519 M 150AX	5
Screwdrivers for slot-head and PHILLIPS® screws	519 M 324H	7
Screwdrivers for TORX® Tamper Resistant screws	519 M 324STX	8
Flat square file, half-round file, round file, square file, triangular file (second cut)	519 M 990A5MD	5
Hammer for mechanics with graphite handle, mallet, pin punches, chisel and centre punch	519 M 382F	7
Assortment with bits and reversible ratchet	692 J32	32



519 M 285A1 519 M 324H 519 M 324STX



519 M 613AEA 519 M 612CLA

495 MAA
U04950627

155
PIECES



Assortment for car repair - 3 drawers

DESCRIPTION	ITEM	PCS.
Hexagonal sockets, ratchet (237 A 1/4"), accessories 1/4" and bits	519 M 613AEA	46
Biexagonal sockets, ratchet (237 A 1/2") and accessories 1/2"	519 M 612CLA	35
Combination wrenches (6-7-8-9-10-11-12-13-14-15-16-17-18-19-21-22-24 mm)	519 M 285A1	17
Screwdrivers for slot-head and PHILLIPS® screws	519 M 324H	7
Screwdrivers for TORX® Tamper Resistant screws	519 M 324STX	8
Pliers for circlips, combination plier, long nose pliers, T-handle wrenches with hex sockets (8-10-13-17 mm), bits set with ratchet	519 M 276C	42



519 M 276C



T-HANDLE WRENCHES

8-10-13-17 mm

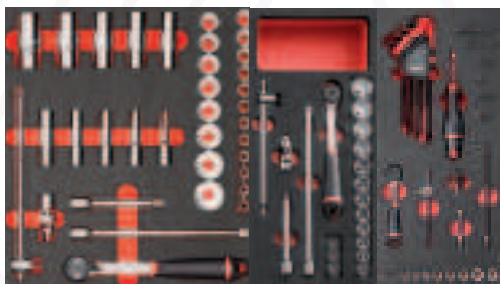

519 M 612CLA 519 M 613BEA 519 M 613AEA

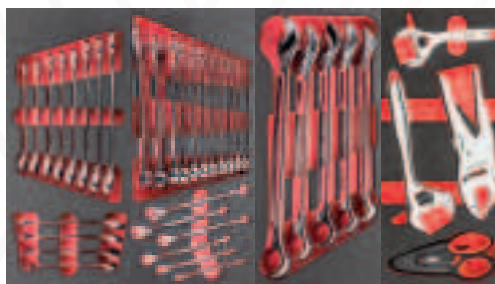

519 M 285KA 519 M 285A1 519 M 285A2 519 M 294B

301
PIECES



495 MC
U04950632

Assortment for MAINTENANCE - 4 drawers

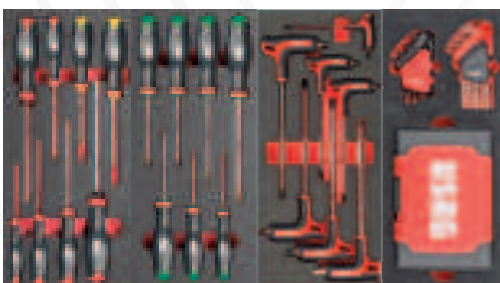

519 M 324H 519 M 324STX 519 M 280HG 519 M 280N1

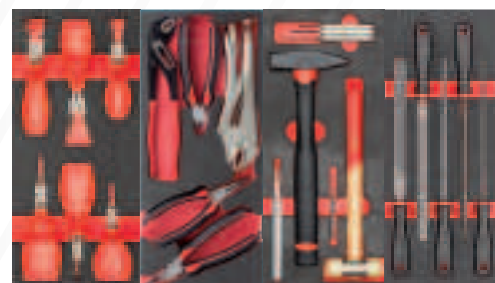

519 M 127C 519 M 150AX 519 M 382F 519 M 990A5MD

PLASTIC TRAYS



519/613AEA 519/613CEA 519 SK692V



519/285A1 519/150AX 519 SK692V

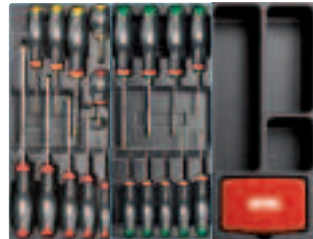

519/324H 519/324TX 519 SK692V + 692 J32



519 SK692V 519/990A1 519/382F



519/613AEA 519/613CEA 519 SK692V + 692 J32



519/324H 519/285A1 519/150AX



T-HANDLE WRENCHES
7-8-10-12-13-17 mm

DESCRIPTION	ITEM	PCS.
Hexagonal sockets, ratchet (237 A 1/4"), accessories 1/4" and bits	519 M 613AEA	46
Hexagonal sockets, ratchet (237 A 3/8") and accessories 3/8"	519 M 613BEA	20
Biexagonal sockets, ratchet (237 A 1/2") and accessories 1/2"	519 M 612CLA	35
Reversible ratchet combination wrenches 8-9-10-11-12-13-14-15-16-17-18-19 mm	519 M 285 KA	12
Combination wrenches (6-7-8-9-10-11-12-13-14-15-16-17-18-19-21-22-24 mm)	519 M 285A1	17
Combination wrenches 27-29-30-32-34 mm	519 M 285A2	5
Adjustable wrenches, lock-grip pliers and scissor	519 M 294B	4
Screwdrivers for slot-head and PHILLIPS® screws	519 M 324H	7
Screwdrivers for TORX® Tamper Resistant screws	519 M 324STX	8
Hexagon keys with handgrip (3-4-5-6-7-8-10 mm)	519 M 280HG	7
Set of keys for TORX® screws and assortment of bits with special shapes	519 M 280N1	117
Pliers for circlips internal and external 15÷25 and 19÷60	519 M 127C	6
Universal pliers, adjustable pliers, cutting nippers, extra-long nose pliers, lock-grip pliers	519 M 150AX	5
Flat square file, half-round file, round file, square file, triangular file (second cut)	519 M 990A5MD	5
Hammer for mechanics with graphite handle, mallet, pin punches, chisel and centre punch	519 M 382F	7

495 PM
U04950630

157
PIECES



Assortment for MAINTENANCE - 4 drawers

DESCRIPTION	ITEM	PCS.
Hexagonal sockets, ratchet (237 A 1/4"), accessories 1/4" and bits	519/613AEA	42
Hexagonal sockets, ratchet (237 A 1/2") and accessories 1/2"	519/613CEA	22
Combination wrenches (6-7-8-9-10-11-12-13-14-15-16-17-18-19-22-24 mm) and angled keys (1,5-2-2,5-3-4-5-6-8-10 mm)	519/285A1	25
Universal pliers, adjustable pliers, cutting nippers, extra-long nose pliers, lock-grip pliers	519/150AX	5
Screwdrivers for slot-head and PHILLIPS® screws	519/324H	10
Screwdrivers for TORX® screws	519/324TX	9
Flat square file, half-round file, round file, triangular file (second cut)	519/990A1	4
Hammers, chisels and pin punches	519/382F	8
Assortment with bits and reversible ratchet	692 J32	32

495 PA
U04950629

142
PIECES



Assortment for car repair - 2 drawers

DESCRIPTION	ITEM	PCS.
Hexagonal sockets, ratchet (237 A 1/4"), accessories 1/4" and bits	519/613AEA	42
Hexagonal sockets, ratchet (237 A 1/2") and accessories 1/2"	519/613CEA	22
Screwdrivers for slot-head and PHILLIPS® screws	519/324H	10
Combination wrenches (6-7-8-9-10-11-12-13-14-15-16-17-18-19-22-24 mm) and angled keys (1,5-2-2,5-3-4-5-6-8-10 mm)	519/285A1	25
Universal pliers, adjustable pliers, cutting nippers, extra-long nose pliers, lock-grip pliers	519/150AX	5
T-handle wrenches with jointed hexagonal socket (7-8-10-12-13-17 mm)	276 CE	6
Assortment with Ribe bits with hole - XZN - TORX® Tamper Resistant	692 J32	32



CAN'T FIND YOUR IDEAL ASSORTMENT?

Go now to kitplanner-gb.usag.it and create it!

Plastic trays



519/127N
U05190716 **4** PIECES
127 N 19÷60 · 127 PN 19÷60 ·
128 N 19÷60 · 128 PN 19÷60.



519/150AX
U05190850 **5** PIECES
133 AX 160 · 134 250 · 150 AX 180 ·
180 C 250 · 188 AX 160.



519/280HG
U05191860 **7** PIECES
280 HG 3-4-5-6-7-8-10.



519/280HGTS
U05191861 **7** PIECES
280 HGTS 3-4-5-6-7-8-10.



519/285A1
U05190785 **25** PIECES
285 6-7-8-9-10-11-12-13-14-15-16-17-
18-19-22-24 280 S9 1,5÷10.

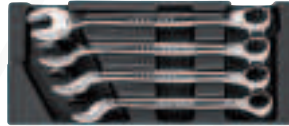

519/285B2
U05190823 **4** PIECES
285 27-29-30-32.



519/285KA1
U05190788 **12** PIECES
285 KA 8-9-10-11-12-13-14-15-
16-17-18-19.



519/294
U05190732 **9** PIECES
204 250 · 294 A 250 · 367 2x110-3x130-
4x145-5x165-6x180-8x200 · 981 A3.



519/322H
U05190772 **10** PIECES
322 0,5x3x75-0,8x4x100-1x5,5x125-
1,2x6,5x150-1,6x8x175 · 322 PH 0x75-1x100-
2x125 · 322 N 0,8x4x30 · 322 NPH 2x30.



519/322STX
U05190831 **6** PIECES
322 STX T10-T15-T20-T25-T30-T40.



519/324H
U05190763 **10** PIECES
324 0,5x3x75-0,8x4x100-1x5,5x125-
1,2x6,5x150-1,2x8x200 · 324 PH 0x75-1x75-
2x100 · 324 N 0,8x4x35 · 324 NPH 2x35.



519/324TX
U05190764 **9** PIECES
324 TX T6x50-T7x50-T8x50-T9x75 · 324 STX
T10x75-T15x75-T20x100-T25x100-T30x125.



519/366
U05190740 **7** PIECES
351 200 · 362 125-150 · 364 125 ·
366 3x125 · 4x150 · 368 4x125.



519/382F
U05190742 **8** PIECES
362 150 · 367 2x100-3x130-4x145-
5x165 · 368 4x125 · 376 35 · 382F 500.



519/613AEA **237 A** **42** PIECES
U05190784
235 1/4" EN 4-4,5-5-5,5-6-7-8-9-10-11-12-13-
14 · 236 1/4" 50-150 · 237 A 1/4" · 240 1/4" ·
241 1/4" · 243 1/4" · 692 S11 · 692 STX/S11 ·
684 1/4"-1/4".



519/613BEA **237 A** **21** PIECES
U05190747
235 3/8" E 6-7-8-9-10-11-12-13-14-15-
16-17-18-19-21-22 · 236 3/8" 125-250 ·
237 A 3/8" · 240 3/8" N · 241 3/8".



519/613CEA **237 A** **22** PIECES
U05190750
235 1/2" EN 10-11-12-13-14-15-16-
17-18-19-20-21-22-24-27-30-32 · 236
1/2" 125-250 · 237 A 1/2" · 240 1/2" N
· 241 1/2".



519/990A1 **4** PIECES
U05190825
990 M PA/200 · 990 M PB/200
990 M PC/200 · 990 M PE/200.



Create your ideal assortment

This is just a selection of the available assortments at Superoffer Conditions: on kitplanner-gb.usag.it you can find 200 modules and 120 assortments to choose!



8 PIECES **XL**
519/280T
U05190727
280 T 2-2,5-3-4-5-6-8-10.



8 PIECES **XXL**
519/276
U05190725
276 CE 7-8-10-11-13-14-17-19.

Bi-colour foam modules



519 M 091A
U05191016 **8** PIECES

091 0,5x3x75-0,8x4x100-1x5,5x125
1,2x6,5x150 · 091 PH 1x100-2x125
· 091 PZ 1x100-2x125.



519 M 127N
U05190937 **4** PIECES

127 N 19÷60 · 127 PN 19÷60 ·
128 N 19÷60 · 128 PN 19÷60.



519 M 150AX
U05190965 **5** PIECES

133 AX 160 · 134 250 · 150 AX 180 ·
180 C 250 · 188 AX 160.



519 M 280HG
U05191945 **7** PIECES

280 HG 3-4-5-6-7-8-10.



519 M 280HGTS
U05191946 **7** PIECES

280 HGTS 3-4-5-6-7-8-10.



519 M 280N1
U05191013 **117** PIECES

280 S9 1,5-2-2,5-3-4-5-6-8-10 · 280 TX/
S8C T10-T15-T20-T25-T27-T30-T40-T45
· 692 J100.



519 M 280TK
U05190935 **6** PIECES

280 TK 2,5-3-4-5-6-8.



519 M 285A1
U05190921 **17** PIECES

285 6-7-8-9-10-11-12-13-14-15-16-
17-18-19-21-22-24.



519 M 285A2
U05190943 **5** PIECES

285 27-29-30-32-34.



519 M 285KA
U05190944 **12** PIECES

285 KA 8-9-10-11-12-13-14-15-
16-17-18-19.



519 M 285KB
U05191060 **12** PIECES

285 KB 8-9-10-11-12-13-14-15-
16-17-18-19.



519 M 294B
U05191015 **4** PIECES

135 A 250 · 207 E · 294 AC · 294 AD 250.



519 M 324H
U05190910 **8** PIECES

324 0,5x3x75-0,8x4x100-1x5,5x125-
1,2x6,5x150 · 324 PH 1x100-2x125
324 D 0,6x3,5x100 324 E 1,6x8x175.



519 M 324STX
U05190911 **7** PIECES

324 STX T10x75-T15x75-T20x100-
T25x100-T27x100-T30x125-T40x150.



519 M 382F
U05190926 **7** PIECES

362 175 · 367 2x100-3x130-6x180
368 3x100 · 376 28 · 382F 500.

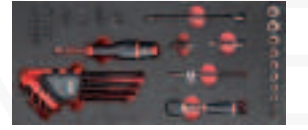

519 M 613AEA **46** PIECES

237 A

235 1/4" EN 5,5-6-7-8-9-10-11-12-13-14 · 236
1/4" 50-100 · 237 A 1/4" · 240 1/4" · 241 1/4" ·
243 1/4" · 280 LTS/S9 · 684 1/4"-1/4" · 660 0,6-
1-1,6 · 660 E 3-4-5-6-8 · 660 PH 1-2-3 · 660 PZ
1-2-3 · 660 STX T15-T20-T25-T27-T30-T40.



519 M 613BEA **20** PIECES

237 A

235 3/8" E 7-8-9-10-11-12-13-14-15-16-
17-18-19-21-22 · 236 3/8" 125-250 ·
237 A 3/8" · 240 3/8" N · 241 3/8".



519 M 613CEA **23** PIECES

237 A

235 1/2" EN 8-10-11-12-13-14-15-16-
17-18-19-21-22-23-24-27-30-32 · 236
1/2" 125-250 · 237 A 1/2" · 240 1/2" N
· 241 1/2".



519 M 990A5MD **5** PIECES

U05191011

990 M PA/200 · 990 M PB/200 · 990 M
PC/200 · 990 M PD/200 · 990 M PE/200.



519 M 276 **7** PIECES **XXL**

U05190936

276 CE 7-8-10-11-13-17-19.

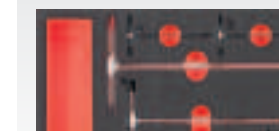

8 PIECES **XL**



519 M 280T
U05191059

280 T 2-2,5-3-4-5-6-8-10.



519 M 276
U05190936

276 CE 7-8-10-11-13-17-19.

Maintenance suitcases



002 JMA U00020011

13 kg | 460 mm | 158 mm | 385 mm

Case with assortment for maintenance

- Case with Aluminium section shell and metal reinforcements
- Double metal closing hinge with lock (key included)
- Three internal panels equipped with elastics to hold tools
- Base with cut-out bi-colour foam



002 JTMA U00020015

14 kg | 485 mm | 200 mm | 377 mm

Tool trolley with assortment for maintenance



**002 JTMA:
WHEELS
INTEGRATED INTO
THE STRUCTURE**



IT CONTAINS AX SERIES PLIERS, SCREWDRIVERS 324 AND THE ADJUSTABLE WRENCH 294 AD!



**181
PIECES**



DESCRIPTION	SIZE	PCS.
Hexagonal sockets 1/2"	10-11-12-13-14-15-16-17-18-19-21-22-24-27-30-32 mm	16
Hexagonal sockets 1/4"	4-4,5-5-5,5-6-7-8-9-10-11-12-13-14 mm	13
Extensions 1/2"	130-250 mm	2
Extensions 1/4"	55-100 mm	2
Reversible ratchet 1/2"		1
Reversible ratchet 1/4"		1
Spinner with handle 1/4"		1
Universal joint 1/2"		1
Universal joint 1/4"		1
Bit-holder socket	1/4-1/4"	1
Combination wrenches	8-9-10-11-12-13-14-15-16-17-18-19 mm	12
Adjustable wrench	250 mm	1
Screwdrivers for slot-head screws	0,4x2,5x50-0,5x3x75-0,8x4x100-1x5,5x125-1,2x6,5x150-1,6x8x175	6
Screwdrivers for PHILLIPS® screws	1x75-2x125	2
Screwdrivers for POZIDRIV®-SUPADRIV® screws	1x75-2x125	2
Angled hexagon keys	1,5-2-2,5-3-4-5-6-8-10 mm	9
Combination pliers	180 mm	1
Adjustable pliers	250 mm	1
Half-round pliers	160 mm	1
Diagonal cutting nippers	160 mm	1
Phase-testing screwdriver		1

DESCRIPTION	SIZE	PCS.
Scissors for electricians		1
Utility knife		1
Tape rule	3 m	1
Mini hacksaw frame		1
Hammer for mechanics	300 g	1
Bits for slot-head screws	3-4-4,5-5-5,5-6-6,5-7-8	9
Bits for PHILLIPS® screws PH	00-0-1(x2)-2(x2)-3-4	8
Bits for POZIDRIV®-SUPADRIV® screws PZ	1-2(x2)-3-4	5
Bits for hex socket screws	1,5-2-2,5-3-4-5-5,5-6-7-8 mm	10
Bits for hex socket screws	1/16-5/64-3/32-7/64-1/8-9/64-5/32-3/16-7/32-1/4	10
TORX® bits	T8-T9-T10-T15-T20-T25-T27-T30-T40-T45	10
TORX® Tamper Resistant bits	T8-T10-T15-T20-T25-T27-T30-T35-T45	9
Tri-Wing bits	1-2-3-4	4
Spanner bits	4-6-8-10-12	5
Torq bits	6-8-10	3
Square bits	0-1-2(x2)-3	5
Clutch bits	1/8-5/32-3/16-1/4-5/16	5
Bits XZN	M5-M6-M8	3
Hexagonal bits for hex socket screws with hole	2-2,5-3-4-5-6	6
Hexagonal bits for hex socket screws with hole	5/64-3/32-7/64-1/8-9/64-5/32	6
Magnetic extensions	1/4"	2



174
PIECES

002 JMP
U00020004

12 kg | 460 mm | 155 mm | 370 mm

Case with assortment for maintenance, inch sizes

- Case with Aluminium section shell and metal reinforcements
- Double metal closing hinge with lock (key included)
- Handle with plastic protection
- Three internal panels equipped with elastics to hold tools
- Blocking system of the folding panel

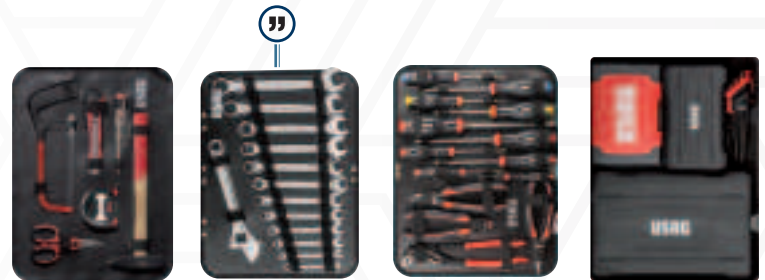

DESCRIPTION	SIZE	PCS.
Assortment with bihexagonal sockets in ABS case, in inches	606 1/2 APOL	15
Assortment with hexagonal sockets in ABS case, in inches	606 1/4 APOL	18
Phase-testing screwdriver 100÷250V	321 F	1
Half-round extra-long nose pliers with straight jaws	133 AX/160	1
Combination pliers	150 AX/180	1
Box-joint adjustable pliers	180 C/250	1
Heavy-duty diagonal cutting nippers	188 AX/160	1
Hacksaw frame with blade tensioner	201 S	1
Scissors for electricians	207 C	1
Utility knife with snap-off blades	220 B1	1

DESCRIPTION	SIZE	PCS.
Set of 8 long angled hexagon keys with spherical head, inch sizes	280 LTSP/S8	8
Combination wrenches, inch sizes	285 P / 1/4-5/16-3/8-7/16-1/2-9/16-5/8-11/16-3/4-13/16-7/8-15/16	12
Adjustable wrenches with quick adjustment	294 AD/250	1
Screwdrivers for slot-head screws	324 0,4x2,5x75-0,5x3x75-0,8x4x100-1x5,5x125-1,2x6,5x150-1,6x8x175	6
Screwdrivers for PHILLIPS® screws	324 PH / 1x75-2x125	2
Screwdrivers for POZIDRIV®-SUPADRIV® screws	324 PZ / 1x75-2x125	2
Hammers for mechanics	382/300	1
Assortment of bits with special shapes - 1/4"	692 J100	100
Professional tape rule with shockproof covering	981 A/3	1

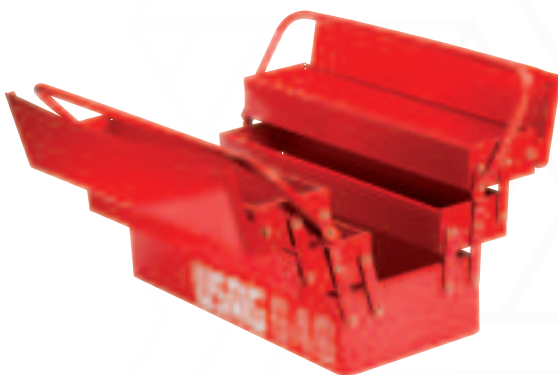

183
PIECES

646/5LM183
U06468002E

15 kg | 560 mm | 320 mm | 220 mm

5
COMPARTMENTS

Long cantilever tool box, five compartments

- Preset for padlock
- Sheet steel casing, anaphoretic process
- Inside dimensions:
lower compartment 537x207x100 mm,
compartments 537x103x52 mm



DESCRIPTION	SIZE	PCS.
Assortment of bits with special shapes	692 J100	100
Assortment with hexagonal sockets	601 1/2 J22	22
Assortment with hexagonal sockets and bits	601 1/4 J34	34
Combination wrenches	285 J/B16 (6-7-8-9-10-11-12-13-14-15-16-17-18-19-22-24 mm)	16
Set with 5 screwdrivers	322 SH5 (322 0,6X3,5X75-0,8X4X100-1X5,5X100-322 PH 1X100-2X125	5
Set with 2 pliers	150 AX/S2 (150 AX 180 - 180 C 250)	2
Hammer 400 gr	382/400	1
Scissors for electricians	207C	1
Mini hacksaw	201	1
Adjustable wrench 200 mm	294 A 200	1



420 mm

MAX
11 kg

CAPACITY
34 L



All equipment on hand

007/1V
U00070001

2,5 kg | mm | 420
340
240

Professional tool bag (empty)

- Model in high strength fabric
- Rigid waterproof bottom
- Inside space for tools
- Aluminium handle with covered handgrip
- 2 front pockets for small objects, 1 side pocket with Velcro closure, 1 side open pocket for quick access to contents, 4 rear pockets protected by the soft top
- 2 internal hooks for tape rule and 6 elastics to hold tools
- 1 pocket with 4 elastics to hold tools and 11 elastics for screwdrivers
- Soft top cover with Velcro



490 mm

MAX
15 kg

CAPACITY
47 L



Front pocket for saw

007 V
U00070002

4 kg | mm | 490
350
220

Professional tool bag (empty)

- Model in high strength fabric
- Rigid waterproof bottom
- Toolholder compartments and front pocket for a saw
- Aluminium handle with covered handgrip
- Transport shoulder strap
- Soft top cover with Velcro



550 mm

MAX
18 kg

CAPACITY
33 L



Telescopic Aluminium handle

007 TXV
U00070065

5,4 kg | mm | 550
440
360

Trolley tool bag (empty)

- Model in high strength fabric
- Telescopic Aluminium handle
- 6 external pockets and 1 front pocket for a saw
- Toolholder compartments
- Aluminium handle with covered handgrip
- Soft top cover with Velcro
- Maximum loading capacity: 18 kg



Front pocket for saw



Wheels with diameter 90 mm



MAX
10 kg

CAPACITY
15 L

007 MCV
U00070008

1 kg | mm | → 360
↑ 280
↙ 190

Tool bag (empty)

- Model in high strength Fabric
- Rigid waterproof bottom
- Internal toolholder compartments
- 3 front pockets with soft top protections
- 3 back pockets
- Handles with PVC cover
- Transport shoulder strap



MAX
9 kg

CAPACITY
8 L

007 FLV
U00070007

600 g | mm | → 310
↑ 220
↙ 140

Tool bag (empty)

- Model in high strength Fabric
- Frontal pocket with zipper closure
- Back pocket with velcro closure
- Rigid reinforced bottom
- Internal tool compartments
- Handles with PVC cover



MAX
25 kg

CAPACITY
9 L

007 PLV
U00070034

1,7 kg | mm | → 450
↑ 170
↙ 180

Bag for plumbers (empty)

- High strength fabric
- Rigid riveted bottom for higher resistance
- Inside pocket for documents
- Can hold a 1.1/2" pipe wrench
- Outside hook for tape rule
- Removable shoulder strap for extra comfort during transport
- Two top handles for better grip
- Closure with Velcro and quick release snap buckles



Portable storage

YouTube



MAX
15 kg

CAPACITY
8 L



Front opening for quick access to content



007 RV
U00070033

1,8 kg | mm → 460
↓ 160
↙ 350

Bag for laptop and tools (empty)

- High strength fabric
- Rigid reinforced bottom
- The front opening allows quick access to content
- Padded compartment for notebook and documents (inside dimensions: 340x240 mm)
- 14 pockets, 2 tool straps and 1 hook for tape rule
- Removable shoulder strap for extra comfort during transport
- Closure with quick release snap buckles

MAX
12 kg

CAPACITY
30 L



Rear pocket for notebook and documents



007 SV
U00070004

3,1 kg | mm → 355
↓ 225
↙ 460

Professional backpack (empty)

- High strength fabric
- Adjustable chest strap
- Padded waist straps to distribute the weight evenly
- Rigid waterproof bottom
- Inside tool-holding space
- Side and front pockets
- Inside document holder
- Padded compartment for notebook and documents (inside dimensions: 340x240 mm)
- Maximum loading capacity: 12 kg



Rear pocket for notebook and documents



007 TV
U00070006

3,5 kg | mm → 350
↓ 500
↙ 200

Professional tool trolley (empty)

- Cabin size dimensions
- High strength fabric
- Inside toolholding spaces
- Front document pocket
- Side pockets with straps for long objects
- Telescopic Aluminium handle
- Wheels integrated into the structure
- Back shoulder straps
- Padded compartment for notebook and documents (inside dimensions: 340x240 mm)
- Maximum loading capacity: 14 kg

MAX
14 kg

CAPACITY
30 L



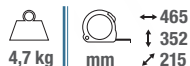

001 RV
U00010004

Tool case in high thickness polypropilene (empty)

- Two inside removable panels with elastics to hold tools
- Lower compartment with mobile separators
- Double key lock



001 TRV
U00010005

Tool trolley in high thickness polypropilene (empty)

- Telescopic Aluminium handle
- Wheels with integrated roll bearings

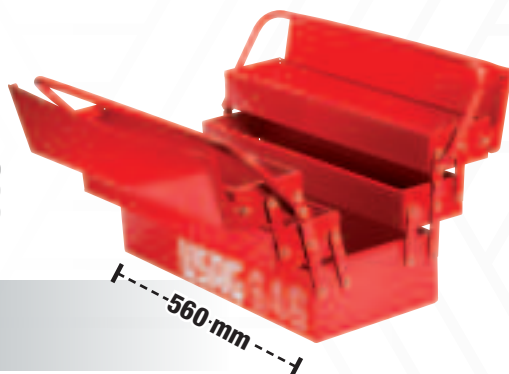

646/5LV
U06460301

Long cantilever tool box, five compartments (empty)

- Preset for padlock
- Sheet steel casing, anaphoretic process



640 A
U06400001

Organizer (empty)

- Transparent cover: contents visible
- 8 removable compartments one of which can be further divided with the 2 dividers provided



641 T

Tool box (empty)

- High resistant plastic material
- 2 compartments for small objects on the cover
- Possibility to close with a padlock (not supplied)
- Foldaway handle
- Inside removable tray

	CODE	L (mm)	P (mm)	H (mm)	Weight
A	U06410004	16" 394	220	162	1,2 kg
B	U06410005	19" 486	266	236	2,1 kg
C	U06410006	24" 595	281	260	2,8 kg



POWER ASSIST SCREWDRIVER 324 XP SPEED OF THE BATTERY, ACCURACY OF YOUR HAND



MAGNETIC BIT HOLDER
with quick release chuck.



HANDLE
ergonomic in oil and chemicals resistant rubber.

IEC 60529



LIGHT
with 5 frontal LED with automatic switch-off at 10 seconds.





AUTOMATIC LOCKING SYSTEM
of the chuck to apply the torque by hand.

CE
EN 60529

TECHNICAL CHARACTERISTICS	
Vibrations (mm/s ²)	1,4
Sound power dB(A)	54
Dimensions (mm)	170x39
Weight (gr)	245



LITHIUM
3.6V - 2.0 Ah
lithium battery.

<15% 
15÷74% 
75÷100% 

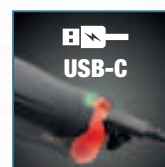

RECHARGEABLE
LED indicator of the battery charge status.
Complete recharge in 70 minutes. (IN: 5V = 3A).

POWER ASSIST SCREWDRIVER



300 RPM
0,9 Nm

ITS SPEED
Works with 300 rpm speed coming from the electric engine.

YOUR ACCURACY
Close the tightening with the accuracy of a standard screwdriver.

10 Nm



High resistance nylon



Bits holding elastics



1/4

324 XP/B16
U03240801

16
PIECES

Bag with power assist screwdriver and bits

- High resistance nylon bag with belt hook
- Bits holder elastics and USB-C cable pocket



SCREWDRIVERS 324 TOP PERFORMANCES

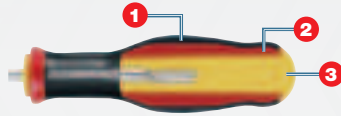

THREE-MATERIAL GRIP

- 1 Outside part in polyurethane resistant to oils and chemicals.
- 2 Body in polyamide resistant to the efforts.
- 3 Inside part in high density polyamide for perfect coupling with the blade.

REINFORCED BLADE

Chrome Silicon Vanadium steel that allows the best mechanical resistance.

TOP PERFORMANCE TIP

Zinc finish. Perfect shape. Treatment against corrosion.

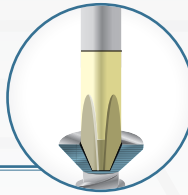

ANTI-ROLLING SHAPE



SOFT GRIP COATING

Better comfort during the use. Greater transmission of the torque.



YouTube



324 SH5

U03240645

Set of 5 screwdrivers for slot-head and PHILLIPS® screws

- 324 D/0,8x4x100 - 1x5,5x125
- 324 PH/0x75 - 1x75 - 2x100

5
PIECES



324 SH8

U03240650

Set of 8 screwdrivers for slot-head and PHILLIPS® screws

- 324 D/0,4x2,5x50
- 324/0,5x3x75-0,8x4x100-1x5,5x125-1,2x6,5x150
- 324 PH/0x75-1x75-2x100

8
PIECES



324 SH12

U03240651

Set of 12 screwdrivers for slot-head, PHILLIPS® and POZIDRIV® -SUPADRIV® screws

- 324 D/0,4x2,5x50
- 324/0,5x3x75-0,8x4x100-1x5,5x125-1,2x6,5x150
- 324 N/1x5,5x35
- 324 PH/0x75-1x75-2x100
- 324 NPH/2x35
- 324 PZ/1x75-2x100

12
PIECES



324 STX/S7

U03240662

Set of 7 screwdrivers for TORX® Tamper Resistant screws

- 324 STX/T10x75-T15x75-T20x100-T25x100-T27x100-T30x125-T40x150

7
PIECES



SCREWDRIVERS 322

QUALITY AND CONVENIENCE.



7
PIECES



322 SH7

U03220254

Set of 7 screwdrivers for slot-head and PHILLIPS® screws

- 322 0,4x2x50-0,5x3x75-0,8x4x100-1x5,5x100-1,2x6,5x150
- 322 PH/1x100-2x125



10
PIECES



322 SH10

U03220255

Set of 10 screwdrivers for slot-head, PHILLIPS® and POZIDRIV® screws

- 322 0,4x2x50-0,5x3x75-0,8x4x100-1x5,5x100-1,2x6,5x150
- 322 PH/OX75-1x100-2x125
- 322 PZ 1X100-2X125

SCREWDRIVERS 091

1000V INSULATION - EN 60900.

USAG SLIM

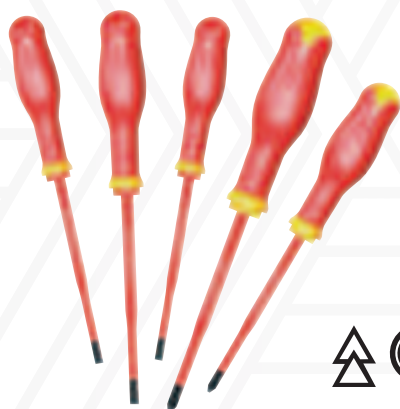

5
PIECES

091 D/SH5

U00910119

Set of 5 SLIM screwdrivers for slot-head and PHILLIPS® screws - 1000 V

- 091 D/0,6x3,5x100-0,8x4x100-1x5,5x125
- 091 DPH/1x100-2x125



5
PIECES

091 SH5

U00910100

Set of 5 screwdrivers for slot-head and PHILLIPS® screws - 1000 V

- 091/0,5x3x75-0,8x4x100-1x5,5x125
- 091 PH/1x100-2x125



8
PIECES

091 SH8

U00910106

Set of 8 screwdrivers for slot-head and PHILLIPS®, POZIDRIV® - SUPADRIV® screws - 1000 V

- 091/0,5x3x75-0,8x4x100-1x5,5x125-1,2x6,5x150
- 091 PH/1x100-2x125
- 091 PZ/1x100-2x125



YouTube

8

PIECES

1/4"

RATCHET SYSTEM



333 K/SH8

U03330142



COMBIDRIVE set with bits

- Delivered with 6 different bits 1/4"

DESCRIPTION	ITEM/SIZE	PCS.
COMBIDRIVE handgrip with 3 functions	333 K	1
COMBIDRIVE magnetic bit-holder	333 1/4 MG	1
Bits for slot-head screws -1/4"	660/0,6x4,5-1x5,5	2
Bits for PHILLIPS® screws -1/4"	660 PH 1-2	2
Bits for hex socket screws -1/4"	660 E 3-4	2



RATCHET SYSTEM



USAG 660 bits
not included

10

PIECES

1/4"

333 K/SB10

U03330143



COMBIDRIVE set in nylon bag

- Delivered with 8 different blades
- Nylon bag with belt hook

DESCRIPTION	ITEM/SIZE	PCS.
COMBIDRIVE handgrip with 3 functions	333 K	1
COMBIDRIVE magnetic bit-holder	333 1/4 MG	1
Reversible COMBIDRIVE blades for slot-head screws	333 I 0,6x3,5-0,8x4/1x5,5-1,2x6,5	2
Reversible COMBIDRIVE blades for PHILLIPS® screws	333 PH 0-1/2-3	2
Reversible COMBIDRIVE blades for TORX® screws	333 TX T8-T9	4
	333 STX T10-T15/T20-T25/T30-T40	4

KEY 280 TQ WITH BIT-HOLDER AND SOCKET SQUARE DRIVE



**210 mm
length**



280 TQ

U02800800



YouTube

T-key bit holder

- Double magnetic bit-holder 1/4"
- Maximum capacity of the bit-holder: 6 mm hexagonal bit or T40 Torx bit
- Single end with 1/4" sockets square drive
- Special Chrome Vanadium steel
- Chrome plated finish

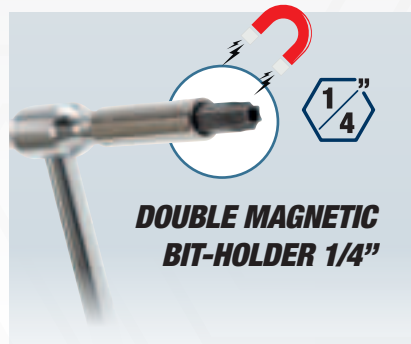

**DOUBLE MAGNETIC
BIT-HOLDER 1/4"**

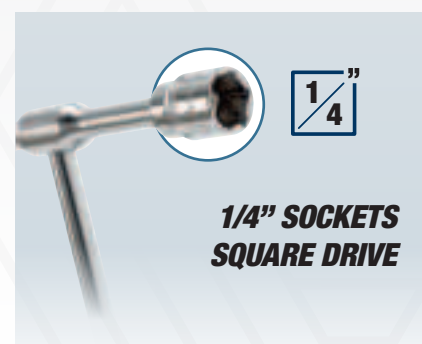

**1/4" SOCKETS
SQUARE DRIVE**



KEY 280 T GUARANTEED SAFETY



**SPECIAL CHROME
VANADIUM STEEL**



USAG KEY



OTHER KEYS

GUARANTEED SAFETY

- + 30% resistance to torsion compared to ISO 2936 rules.
- When the breaking torque is reached, the key will deform without breaking.



FIX BAR
Maximum resistance.

**7
PIECES**



280 T/SE7
U02800903

Set of 7 T-handle hexagon keys
• 280 T/2-2,5-3-4-5-6-8 mm

**8
PIECES**



280 TTX/SE8
U02800686

Set of 8 T-handle keys for TORX® screws
• 280 TTX/T6-T7-T8-T9-T10-T15-T20-T25

**6
PIECES**



280 TTS/SE6
U02800760

Set of 6 T-handle hexagon keys with spherical head
• 280 TTS/2,5-3-4-5-6-8 mm



Spherical head

**6
PIECES**



280 TK/SE6
U02800020

Set of 6 T-handle hexagon keys with sliding bar
• 280 TK/2,5-3-4-5-6-8 mm



Sliding bar

ANGLED HEXAGON KEYS 280 HG WITH HANDGRIP



GUARANTEED SAFETY

- + 30% resistance to torsion compared to ISO 2936 rules.
- When the breaking torque is reached, the key will deform without breaking.

Same blade as the 280 T keys



ERGONOMIC BIMATERIAL HANDGRIP

SPECIAL CHROME VANADIUM STEEL



6
PIECES



280 HG/SE6

U02801460

Set of 6 angled hexagon keys with bimaterial handgrip

- 280 HG/2,5-3-4-5-6-8 mm

6
PIECES



280 HGTS/SE6

U02801463

Set of 6 angled hexagon keys with spherical head and bimaterial handgrip

- 280 HG/2,5-3-4-5-6-8

6
PIECES



280 HAP/SE6

U02800462

Set of 6 angled hexagon keys with handgrip, inch sizes

- 280 HAP 1/4-7/32-5/32-5/16-3/8-3/16

6
PIECES



280 HATX/SE6

U02800464

Set of 6 angled keys with handgrip for TORX® screws

- 280 HATX/T8-T10-T15-T20-T25-T30

Hexagonal keys and bits

YouTube



32
PIECES



280 g | mm | 138
30
98



692 J32
U06920042

Assortment with bits and reversible ratchet - 1/4"

DESCRIPTION	SIZE	PCS.
Bits for slot-head screws	4-5,5-6,5-8	4
Bits for PHILLIPS® screws	PH 1-2-3	3
Bits for POZIDRIV® screws	PZ 1-2-3	3
Bits for hex socket screws	3-4-5-6	4
Bits for TORX® screws	T8-10-15-20-20-25-25-30-40	9
Bits for TORX® Tamper Resistant screws	STX 10-15-20-25-27-30-40	7
Magnetic bit-holder adapter		1
Ratchet		1



49
PIECES



280 g | mm | 138
30
98



692 J49
U06920041

Assortment with bits - 1/4"

DESCRIPTION	SIZE	PCS.
Bits for slot-head screws	4-4,5-5,5-6,5-6,5-8	6
Bits for PHILLIPS® screws	PH 1-1-2-2-2-3	6
Bits for POZIDRIV® screws	PZ 1-1-2-2-2-3-3	7
Bits for hex socket screws	2-3-3-4-4-5-5-6-6	9
Bits for TORX® screws	TX 10-10-15-15-20-20-25-25-30-30	10
Bits for TORX® Tamper Resistant screws	STX 10-15-15-20-20-25-25-30-30-40	10
Magnetic bit-holder adapter		1



Colour code for quick identification of the bit

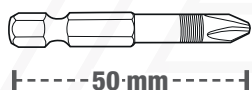

664 S25
U06640111

Assortment with long bits for impact wrenches - 1/4"

- Plastic box

25
PIECES



800 g | mm | 215
45
150

DESCRIPTION	SIZE	PCS.
Bits for slot-head screws	3-4-5-6	4
Bits for PHILLIPS® screws	1-2(x2)-3(x1)	5
Bits for POZIDRIV® screws	1-2(x2)-3(x1)	5
Bits for TORX® screws	T15-T20-T25-T30-T40	5
Bits for hex socket screws	2-3-4-5-5,5	5
Magnetic bit-holder adapter		1

664 B/S7
U06640015

Assortment with magnetic socket bits for hexagonal screws 1/4"

- Compact plastic box



7
PIECES



5,5-6-7-8
10-12-13 mm

300 g | mm | 138
30
98



Hexagonal keys and bits



900 g | 215 mm
45 mm | 150

DESCRIPTION	SIZE	PCS.
Bits for slot-head screws	3-4-4,5-5-5,5-6-6,5-7-8	9
Bits for PHILLIPS® screws	PH 00-0-1-1-2-2-3-4 PZ 1-2-2-3-4	13
Bits for hex socket screws	1,5-2-2,5-3-4-5-5,5-6-7-8 mm 1/16-5/64-3/32-7/64-1/8-9/64-5/32-3/16-7/32-1/4"	20
Bits for TORX® screws	T 8-9-10-15-20-25-27-30-40-45	10
Bits for TORX® Tamper Resistant screws	STX 8-10-15-20-25-27-30-35-40	9
Tri-Wing bits	1-2-3-4	4
Spanner bits	4-6-8-10-12	5
Torq-set bits	6-8-10	3
Square bits	0-1-2-2-3	5
Clutch bits	1/8-5/32-3/16-1/4-5/16	5
Bits XZN	M5-M6-M8	3
Bits for hex socket screws with hole	2-2,5-3-4-5-6 mm - 5/64-3/32-7/64-1/8-9/64-5/32"	12
Magnetic bit-holder adapter	1/4x60mm	2

692 J100
U06920043

Assortment of bits with special shapes - 1/4"

100
PIECES

1/4



COMPACT SUPPORTS WITH QUICK EXTRACTION SYSTEM



Watch the video



YouTube



9
PIECES



280 LTS/S9
U02800084

Set of 9 long angled hexagon keys with spherical head

- 280 LTS/1,5-2-2,5-3-4-5-6-8-10 mm

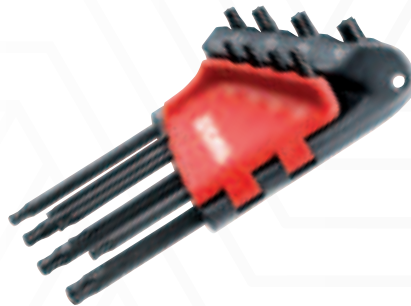

8
PIECES



280 LTSTX/S8
U02800078

Set of 8 long angled keys with spherical head for TORX® screws

- 280 LTSTX/T10-T15-T20-T25-T27-T30-T40-T45



9
PIECES



280 XLTS/S9
U02800184

Set of 9 long hexagon keys with spherical head

- 280 XLTS/1,5-2-2,5-3-4-5-6-8-10 mm

RANGE OF PLIERS "AX" CHROME PLATED FINISH. BIMATERIAL HANDLES.



Can cut up to 2 mm piano wire with 30% less effort in comparison to the maximum value stated on the European rules ISO5749 (cutting nippers) - ISO5746 (pliers)

YouTube



CUTTING EDGES WITH INDUCTION HARDENING
for maximum efficiency in cutting the piano wire.

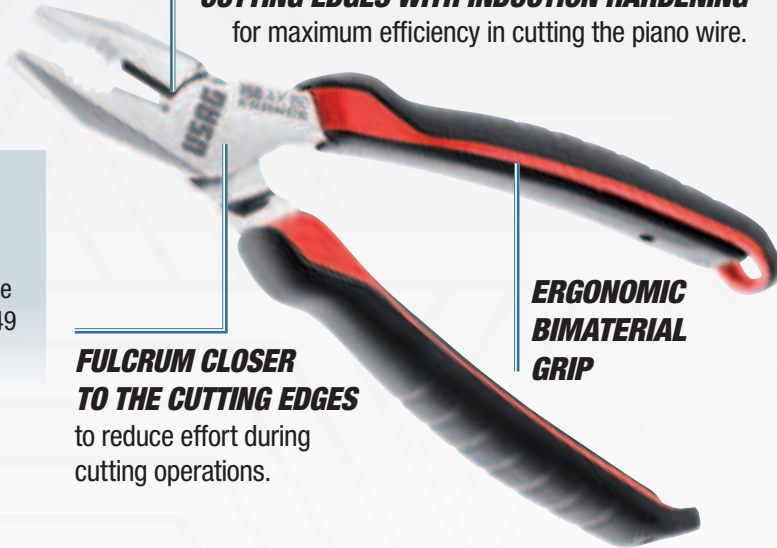

FULCRUM CLOSER TO THE CUTTING EDGES
to reduce effort during cutting operations.

ERGONOMIC BIMATERIAL GRIP

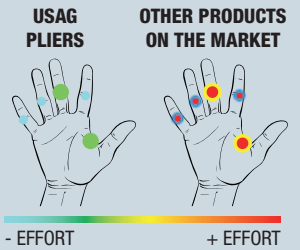

Minimum effort resulting from the studies on muscle strain made by the prestigious US Ergonomics Institute

3
PIECES



150 AX/SE3
U01500201

Assortment with combination pliers, extra-long half-round nose pliers and cutting nippers

- Combination pliers 150 AX 180
- Half-round extra-long nose pliers with straight jaws 133 AX 160
- Diagonal cutting nippers 188 AX 160

3
PIECES



1000 V

085 EX/SE3
U00850121

Assortment with combination pliers, half-round nose pliers with straight jaws and diagonal cutting nippers - 1000 V

- Half-round extra-long nose pliers with straight jaws 081 EX 160
- Combination pliers 085 EX 180
- Diagonal cutting nippers 087 EX 160



ROUND PROFILES
Special notch on the toothing for a strong grip of round bars, also threaded

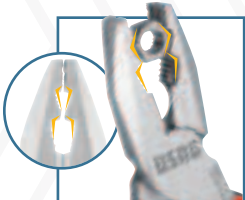

HEXAGONAL PROFILES
Jaw shape studied to grip hexagonal material

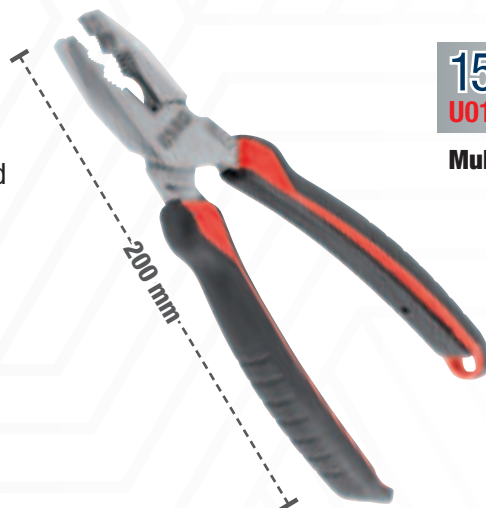

155 AX
U01550001

Multifunction combination pliers

Multifunction combination pliers

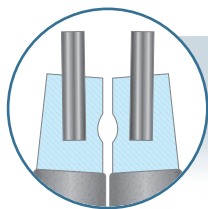

MAXIMUM RESISTANCE

Spring steel tips inserted into the nose.

4

PIECES



4

PIECES



127 N/SE4S

U01270046

Small sizes

Set of 4 pliers for circlips

- Pliers for internal circlips **127 N** 12÷25, **127 PN** 12÷25, pliers for external circlips **128 N** 10÷25, **128 PN** 10÷25

127 N/SE4

U0127900P

Large sizes

Set of 4 pliers for circlips

- Pliers for internal circlips **127 N** 19-60, **127 PN** 19-60, pliers for external circlips **128 N** 19-60, **128 PN** 19-60

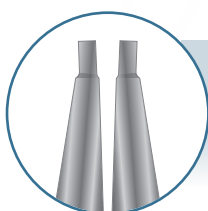

MAXIMUM ACCESSIBILITY

Nose and tip in a single body.

4

PIECES

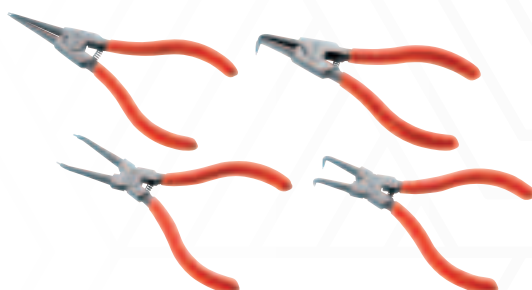

4

PIECES



127 C/SE4S

U01270045

Small sizes

Set of 4 pliers for circlips

- Pliers for internal circlips **127 C** 12÷25, **127 CP** 12÷25, pliers for external circlips **128 C** 10÷25, **128 CP** 10÷25

127 C/SE4

U01270040

Large sizes

Set of 4 pliers for circlips

- Pliers for internal circlips **127 C** 19-60, **127 CP** 19-60, pliers for external circlips **128 C** 19-60, **128 CP** 19-60

PLIER WRENCH 174 CX PLIER AND WRENCH IN THE SAME TOOL

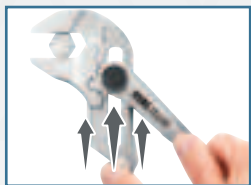

QUICK ADJUST CLOSING
without pushing the button.

MAX. CAPACITY
58 mm

METRIC SCALE

20 POSITIONS RAIL



PVC COVERED HANDLES

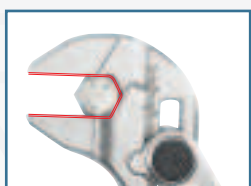

17 mm

PARALLEL JAWS

FLAT JAWS

Internal design that fits perfectly
the hexagon.

174 CX

U01740001

Adjustable plier wrench

- Length: 250 mm



YouTube

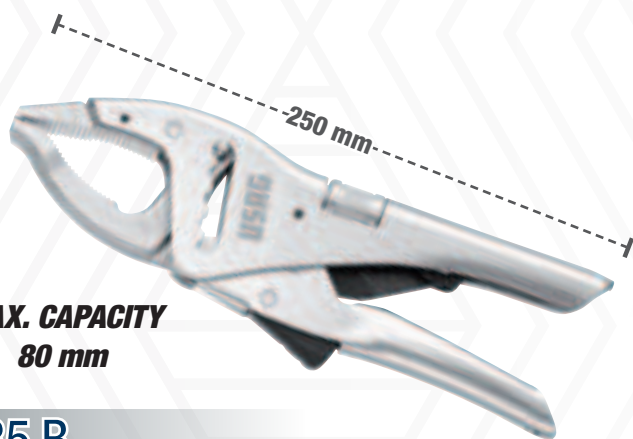

MAX. CAPACITY
80 mm

135 B

U01350510

Lock-grip rack-type pliers with long jaws

- Forged jaws
- Tothing designed for a perfect grip even on round surfaces
- Patented opening system integrated in the handles
- Roller grip adjustment integrated in the handle
- 5-positions rack



FLUSH CUT



FOR PLASTICS

186 C

Diagonal cutting nippers with flush cutting edge for plastics

- Rounded thinned jaws
- Spring-action
- Handles sheated in PVC

CODE	L	
U01860060	150 mm	22 mm
U01860061	180 mm	27 mm

LARGE OPENING CAPACITY +20%



YouTube

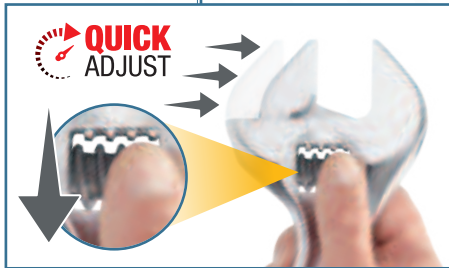

**QUICK ADJUSTMENT
BY PULLING BACK THE ROLL**

**PRECISE REGULATION
BY ROTATING THE ROLL**

294 AD

Adjustable wrenches with quick adjustment

- Quick adjustment by pulling back the roll
- Large capacity: opening +20% compared to the standard
- Double graduated scale: millimetres and inches
- Head angled at 22°
- Steel roll
- Hanging hole
- Chrome plated finish

CODE	L	OPENING
U02940011	110 mm - 4"	17 mm
U02940012	150 mm - 6"	23 mm
U02940013	200 mm - 8"	33 mm
U02940014	250 mm - 10"	38 mm
U02940015	300 mm - 12"	41 mm
U02940016	380 mm - 15"	50 mm
U02940017	460 mm - 18"	63 mm

LARGE OPENING CAPACITY +20%



YouTube

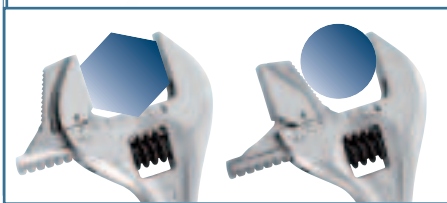

**STANDARD
POSITION**

**REVERSED
JAW**

**REVERSE THE
MOVABLE JAW**
to drive an hexagonal
or a round profile

294 AG

Reversible adjustable wrenches with handle

- In the standard position it can drive a hexagonal profile
- By reversing the movable jaw, it can drive a round profile
- Large capacity: opening +20% compared to the standard
- Double graduated scale: millimetres and inches
- Ergonomic bimaterial handle
- Head angled at 22°
- Steel roll
- Hanging hole
- Chrome plated finish

CODE	L	OPENING
U02940023	200 mm - 8"	33 mm
U02940024	250 mm - 10"	38 mm
U02940025	300 mm - 12"	41 mm



**MAX
OPENING
34 MM**

Only 150 mm

294 AC

U02940010

Short adjustable wrench

- Length reduced of 46% compared to a standard wrench
- Same jaw opening of a 12" wrench
- Lightweight and compact for optimum accessibility
- Regulation by steel roll
- Scale in millimeters on the wrench head
- Chrome plated finish



-46%

**LENGTH REDUCED OF
46% COMPARED TO A
STANDARD WRENCH**



COMBINATION WRENCH 285 X PERFECT ON NEW HEXAGON AND EFFECTIVE ON DAMAGED BOLT

INCLINED OPEN END

angled at 15° as regards to wrench axis.

DOUBLE T SECTION

Excellent resistance to flexion.

SPECIAL RING SHAPE

Ideal for operations on nuts difficult to reach.

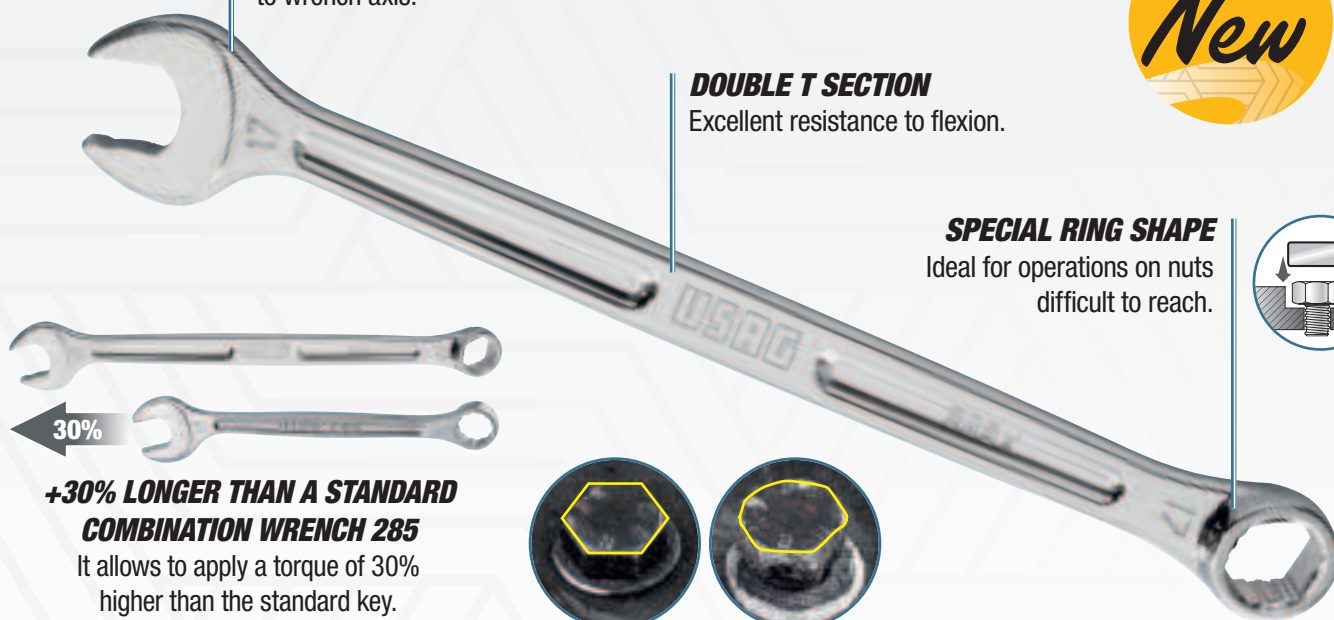
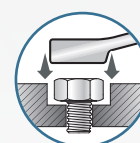

30%

+30% LONGER THAN A STANDARD COMBINATION WRENCH 285

It allows to apply a torque of 30% higher than the standard key.



SPECIAL PROFILES

The internal profile of open/box end is designed to works on new hexagons and even on very damaged hexagons.



8
PIECES

285 X/B8
U02850950

- Set of 8 combination wrenches with special profiles
- 285 X/8-10-11-12-13-14-17-19 mm.
 - Supplied in a high strength fabric roll-up bag



12
PIECES

285 X/SE12
U02850951

- Set of 12 combination wrenches with special profiles
- 285 X/8-9-10-11-12-13-14-15-16-17-18-19 mm.





COMBINATION WRENCH 285 RESISTANCE AND ERGONOMIC.



YouTube

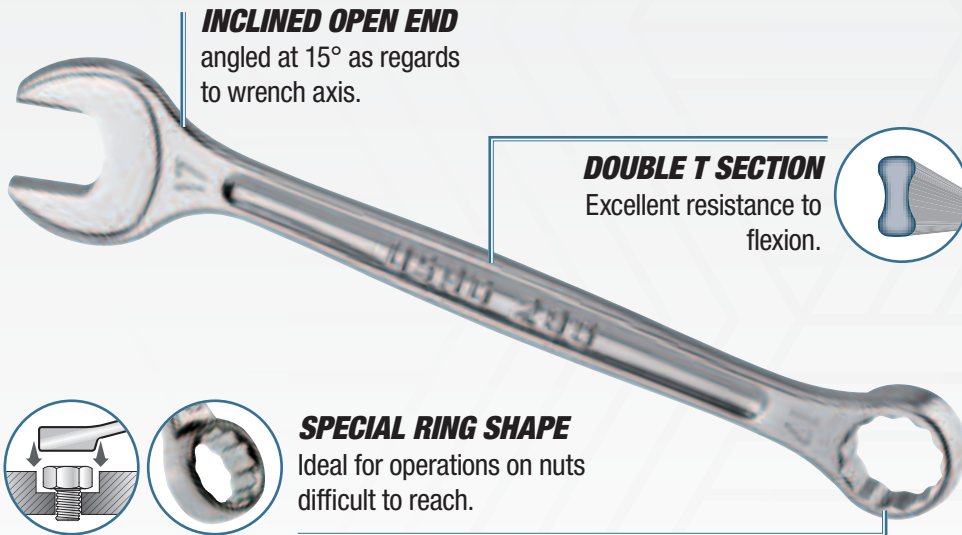

INCLINED OPEN END
angled at 15° as regards to wrench axis.

DOUBLE T SECTION
Excellent resistance to flexion.

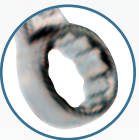
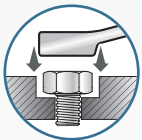
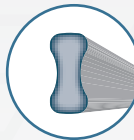

SPECIAL RING SHAPE
Ideal for operations on nuts difficult to reach.



TOP PERFORMANCE
The open end and the bihexagonal ring of the combination wrench 285 exceed the static torsion test, reaching a torque of +50% compared to the test value required by the standard ISO 1711-1

**ISO 1711-1
SAE AS 954E**

8
PIECES

8÷19 mm

285 DS8
U02850863

Set of 8 combination wrenches

- 285/8-10-11-12-13-14-17-19 mm
- Supplied with plastic holder

12
PIECES

7÷19 mm

285 DS12
U02850864

Set of 12 combination wrenches

- 285/7-8-10-11-12-13-14-15-16-17-18-19 mm
- Supplied with plastic holder

**SIZE
IN INCHES**

1/4÷9/16"

285 P/SE5
U02850856

Set of 5 combination wrenches, inch sizes

- 285 P 1/4-3/8-7/16-1/2-9/16"

5
PIECES

6÷32 mm

285 SE26
U02850861

Set of 26 combination wrenches

- 285/6-7-8-9-10-11-12-13-14-15-16-17-18-19-20-21-22-23-24-25-26-27-28-29-30-32 mm

26
PIECES

REVERSIBLE RATCHET COMBINATION WRENCHES 285 KA WITH LOCKING RING.

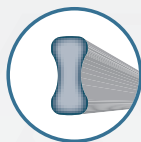
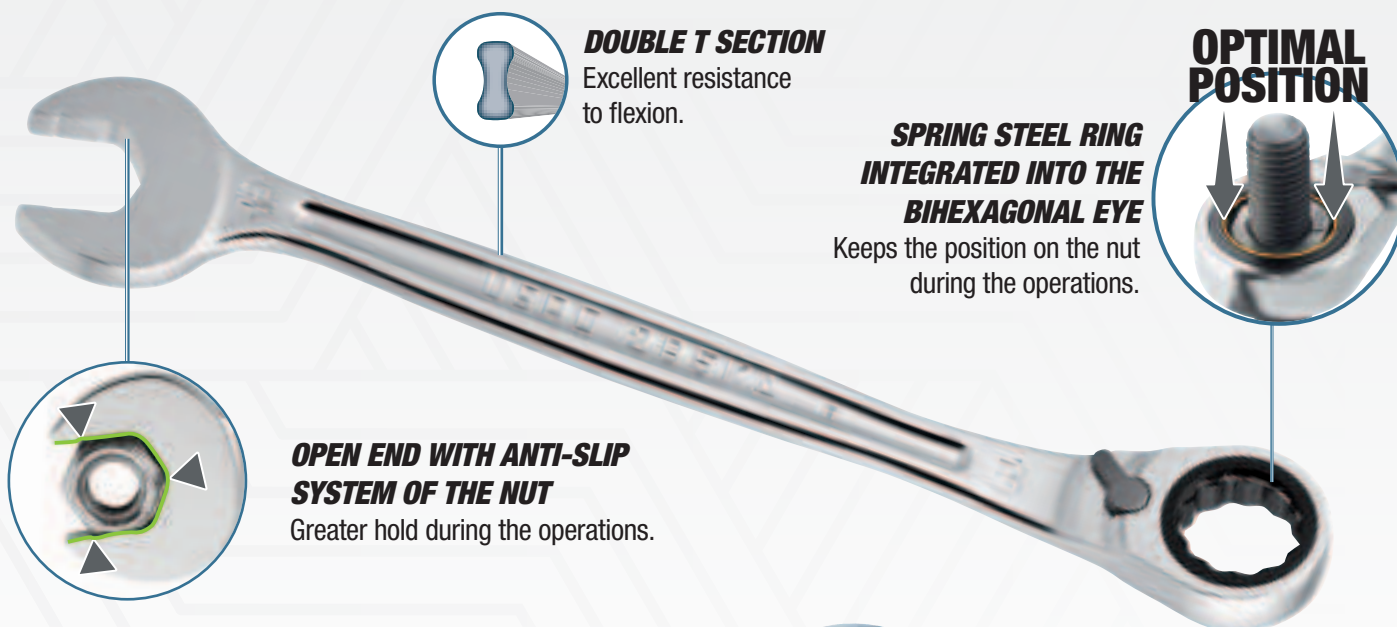

DOUBLE T SECTION
Excellent resistance to flexion.



OPTIMAL POSITION

**SPRING STEEL RING
INTEGRATED INTO THE
BIHEXAGONAL EYE**
Keeps the position on the nut during the operations.

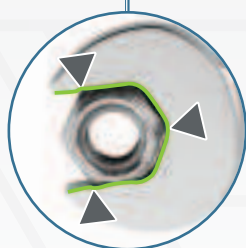

**OPEN END WITH ANTI-SLIP
SYSTEM OF THE NUT**
Greater hold during the operations.

STRONG RATCHET

The ratcheting ring of USAG wrenches 285 KA exceeds static torsion tests, reaching a torque of +50% compared to the value required by ISO rules 1711-1



YouTube

8
PIECES

8÷19 mm



285 KA/DS8

U02856058

Set of 8 reversible ratchet combination wrenches with locking ring

- 285 KA 8-10-11-12-13-14-17-19 mm
- Supplied with plastic holder

12
PIECES

7÷19 mm



285 KA/DS12

U02856062

Set of 12 reversible ratchet combination wrenches with locking ring

- 285 KA/7-8-10-11-12-13-14-15-16-17-18-19 mm
- Supplied with plastic holder

HINGED JOINTED REVERSIBLE RATCHET COMBINATION WRENCH 285 KF

DOUBLE T SECTION
Excellent resistance to flexion.

OPEN END WITH ANTI-SLIP SYSTEM OF THE NUT
Greater hold during the operations.

JOINTED HEAD
180°

5
PIECES

8÷19 mm

285 KF/SE5
U02856160

Set of 5 hinged jointed reversible ratchet combination wrenches

- 285 KF 8-10-13-17-19 mm

8
PIECES

8÷19 mm

285 KF/DS8
U02856158

Set of 8 hinged jointed ratchet combination wrenches

- 285 KF 8-10-11-12-13-14-17-19 mm
- Supplied with plastic holder

285 KB FLAT RATCHET COMBINATION WRENCH

FLAT RATCHET HEAD
ideal for hard to reach places

CHANGE OF ROTATION
turning the wrench 180°

New

7
PIECES

8÷19 mm

285 KB/DS7
U02856341

Set of 7 flat ratchet combination wrenches

- 285 KB/8-10-12-13-14-17-19 mm.
- Supplied with plastic holder

New

12
PIECES

8÷19 mm

285 KB/DS12
U02856342

Set of 12 flat ratchet combination wrenches

- 285 KB/8-9-10-11-12-13-14-15-16-17-19 mm.
- Supplied with plastic holder

Just **USAG**

285 J COMBINATION WRENCH



OPEN END ANGLED AT 15°

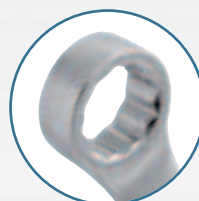

BIHEXAGONAL HEAD BENT AT 15°



7
PIECES

8÷19 mm

285 J/DS7
U02851745

Set of 7 combination wrenches

- 285 J/8-10-12-13-14-17-19 mm.
- Supplied with plastic holder



12
PIECES

8÷19 mm

285 J/DS12
U02851746

Set of 12 combination wrenches

- 285 J/8-9-10-11-12-13-14-15-16-17-19 mm.
- Supplied with plastic holder

8
PIECES

6÷22 mm



252 N/SR8
U02520862

Set of 8 double ended open jaw wrenches

- 252 N/6x7-8x9-10x11-12x13-14x15-16x17-18x19-20x22 mm

8
PIECES

7÷19 mm

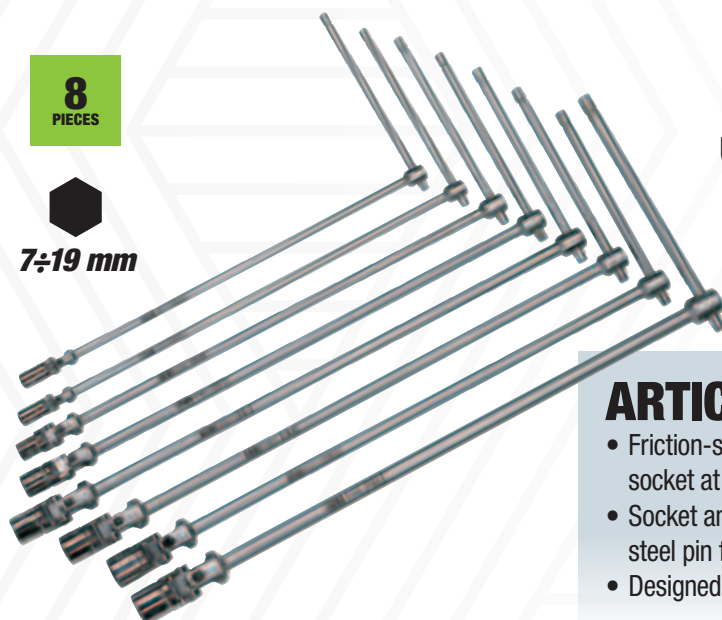

UNI 6743

276 CE/SE8
U02760484

Set of 8 T-handle wrenches with jointed hexagonal socket

- 276 CE/7-8-10-12-13-14-17-19 mm

ARTICULATED JOINT

- Friction-spring to allow presetting of the socket at the desired angle
- Socket and joint are fixed with a riveted steel pin for great stability.
- Designed and manufactured according to UNI 6743 rules.





38
PIECES

1/4"



900 g | mm | 155
50
95

609 1/4" EB

U06090002



Assortment with hexagonal sockets and bits in bimaterial box

- Compact bimaterial box with soft-touch covering

DESCRIPTION	ITEM/SIZE	PCS.
Hexagonal sockets	235 1/4" EN 5,5-6-7-8-9-10-11-12-13-14 mm	10
Extensions	236 1/4" 50-100	2
Reversible ratchet with sealed mechanism	237 B 1/4"	1
Universal joint	241 1/4"	1
Spinner with handle	243 1/4"	1
Bits for slot-head screws -1/4"	660 0,6x4,5-1x5,5-1,2x6,5	3
Bits for PHILLIPS® screws -1/4"	660 PH 1-2-3	3
Bits for POZIDRIV® - SUPADRIV® screws -1/4"	660 PZ 1-2-3	3
Bits for hex socket screws -1/4"	660 E 2-3-4-5-6	5
Bits for TORX® Tamper Resistant screws -1/4"	660 STX T10-T15-T20-T25-T27-T30-T40	7
Socket-holder bit -1/4"	660 Q 1/4"	1
Bit-holder sockets	684 1/4"-1/4"	1



YouTube

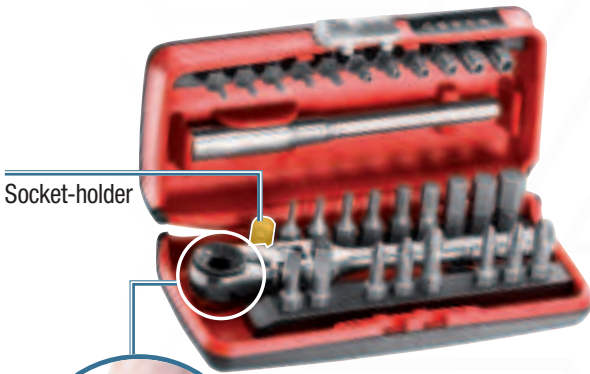

Socket-holder

31
PIECES

1/4"



350 g | mm | 120
35
65



606 1/4" SK

U06060012

Assortment with bits and reversible ratchet

DESCRIPTION	ITEM/SIZE	PCS.
Reversible ratchet	237 1/4" SFK	1
Bits for slot-head screws -1/4"	660 0,5x4-1x5,5	2
Bits for hex socket screws -1/4"	660 E 1,5-2-2,5-3-4-5-6-7-8	9
Bits for PHILLIPS® screws -1/4"	660 PH 1-2-3	3
Bits for POZIDRIV® - SUPADRIV® screws -1/4"	660 PZ 1-2-3	3
Socket-holder bit - 1/4"	660 Q 1/4"	1
Bits for TORX® Tamper Resistant screws -1/4"	660 STX T10-T15-T20-T25-T27-T30-T40	7
Bits for TORX® screws -1/4"	660 TX T6-T7-T8-T9	4
Magnetic bit-holder adapter - 1/4"	672 1/4" MG 100	1



YouTube

610 1/4" EFK

U06100001

Assortment with short hexagonal sockets and reversible ratchet in bimaterial box



11
PIECES

1/4"

11 mm



265 g | mm | 120
35
65

5,5-6-7-8-9-10-
11-12-13-14 mm

SHORT HEXAGONAL SOCKETS

They offer more accessibility also using a standard ratchet.

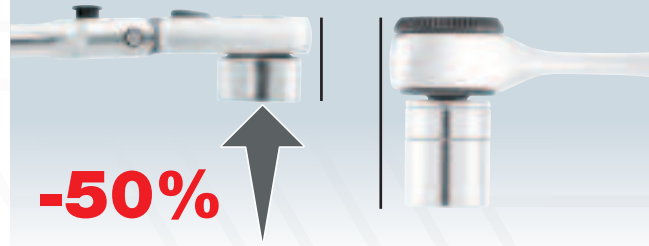

YouTube

REVERSIBLE RATCHET 237 A WITH SEALED MECHANISM IP51.



Inversion system integrated into the cover



Head thickness reduced, compared to standard models



YouTube



CONICAL HANDLE
in anti-slip bimaterial.

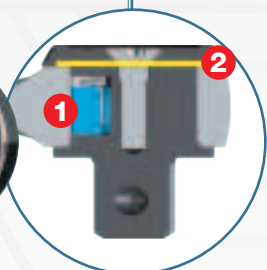

1. New patented pawl
2. Protective diaphragm

TOP PERFORMANCE

1. Static torsional resistance:
+30% compared to the value required by ISO 3315 rules, with the patented pawl.
2. Effort resistance:
assures twice the tightening cycles compared to standard products on the market, with IP51 protection.



23
PIECES

1/2"



3 kg | 330 mm | 60 | 215

606 1/2" EA
U06060302

Assortment with hexagonal sockets in ABS case

- High resistance ABS case with quick closing system

DESCRIPTION	ITEM/SIZE	PCS.
Hexagonal sockets	235 1/2 EN 8-9-10-11-12-13-14-15-16-17-18-19-21-22-23-24-27-30-32	19
Extensions	236 1/2 125-250	2
Universal joint	241 1/2	1
Reversible ratchet with sealed mechanism (certified IP51) 237 A 1/2		1



19
PIECES

1/4"



1 kg | 210 mm | 60 | 130

606 1/4" EA
U06060101

Assortment with hexagonal sockets in ABS case

- High resistance ABS case with quick closing system

DESCRIPTION	ITEM/SIZE	PCS.
Hexagonal sockets	235 1/4 EN 4-4.5-5-5.5-6-7-8-9-10-11-12-13-14	13
Extensions	236 1/4 50-100	2
Universal joint	241 1/4	1
T-handle with sliding square drive	240 1/4	1
Spinner with handle	243 1/4	1
Reversible ratchet with sealed mechanism (certified IP51) 237 A 1/4		1

THE TOP FOR HARD TO REACH AREAS



608 1/4" EAK
U06080305

↔ 435
↓ 70
↗ 270
mm

50
PIECES

1/4"



Assortment with hexagonal sockets in ABS case

- High resistance ABS case with quick closing system
- The inside tray is studied to be stored in USAG roller cabinet drawers
- Empty inner foam module: code U05191020Q

DESCRIPTION	ITEM/SIZE	PCS.
Hexagonal sockets	235 1/4 EN 4-4,5-5-5,5-6-7-8-9-10-11-12-13-14	13
Reversible ratchet with revolving handle	237 1/4 AK	1
Spinner with handle	243 1/4	1
Flexible spinner with handle	243 1/4 SN	1
T-handle key with jointed square drive	273 1/4 Q	1
Assortment with bits and reversible ratchet (31 pcs.)	606 1/4 SK	31
Adapter	247 1/4	1
Bit-holder sockets	684/1	1



T-handle key with jointed square drive



Flexible spinner with handle



Reversible ratchet with revolving handle



Hinged ratchet for bits
180°

REVERSIBLE RATCHET WITH REVOLVING HANDLE

1/4"

237 1/4" AK
U02370003

Reversible ratchet with revolving handle

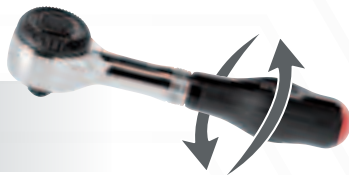

1/2"

237 1/2" AK
U02370009

Reversible ratchet with revolving handle

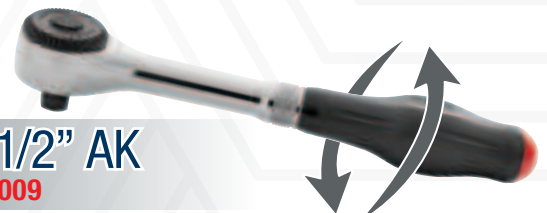

17
PIECES

3/4"



612 3/4" EB
U06120017



↔ 425
↓ 83
↗ 395
mm
13 kg

Assortment in sheet steel box with hexagonal sockets

DESCRIPTION	ITEM/SIZE	PCS.
Hexagonal sockets	235 3/4 N 22-23-24-26-27-28-30-32-36-38-41-46-50	13
Extensions	236 3/4 200-400	2
T-handle with sliding square drive	240 3/4 N	1
Reversible ratchet with sealed mechanism	237 B 3/4	1

612 3/4" B
U06120016



BIHEXAGONAL SOCKETS

Assortment in sheet steel box with bihexagonal sockets



16
PIECES

1/2"

1/4"



1 kg | mm | 190
58
144

601 1/4-1/2" JTX16

U06010009

Assortment with TORX® sockets in modular box

DESCRIPTION	SIZE	PCS.
TORX® sockets 1/4"	E6-E7-E8-E10	4
TORX® sockets 1/2"	E12-E14-E16-E18	4
TORX® socket bits 1/4"	T10-T15-T20-T25	4
TORX® socket bits 1/2"	T30-T40-T45-T50	4



34
PIECES

1/4"



1 kg | mm | 190
58
144

601 1/4" J34

U06010001

Assortment with hexagonal sockets and bits in modular box

DESCRIPTION	SIZE	PCS.
Hexagonal sockets 1/4"	4-4,5-5-5,5-6-7-8-9-10-11-12-13-14	13
Reversible ratchet 1/4"		1
Spinner with handle 1/4"		1
Extensions 1/4"	55-100	2
Bits for slot-head screws 1/4"	4-5,5-6	3
Bits for PHILLIPS® screws 1/4" PH	1-2-3	3
Bits for hexagonal screws 1/4"	4-5-6	3
TORX® bits 1/4"	T10-T15-T20-T25-T30-T40	6
Universal joint 1/4"		1
bit-holder socket 1/4-1/4"		1



22
PIECES

1/2"



4 kg | mm | 375
80
186

601 1/2" J22

U06010003

Assortment with hexagonal sockets in modular box

DESCRIPTION	SIZE	PCS.
Hexagonal sockets 1/2"	8-10-11-12-13-14-15-16-17-18-19-21-22-24-27-30-32	17
Reversible ratchet 1/2"		1
Extensions 1/2"	130-250	2
Universal joint 1/2"		1
T-handle 1/2"		1

USAG QUALITY AT A *Just* PRICE



1/4"
1/2"

8 kg | 415 mm | 92 | 283

100
PIECES



601 1/4-1/2" J100
U06010011

Assortment with hexagonal sockets and bits in modular box



The boxes are modular with USAG roller cabinet drawers

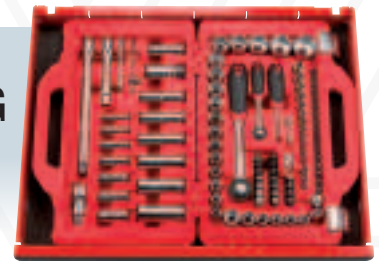

1/4"
1/2"

7 kg | 415 mm | 92 | 283

82
PIECES



601 1/4-1/2" J82
U06010010

Assortment with hexagonal sockets and combination wrenches in modular box



The boxes are modular with USAG roller cabinet drawers

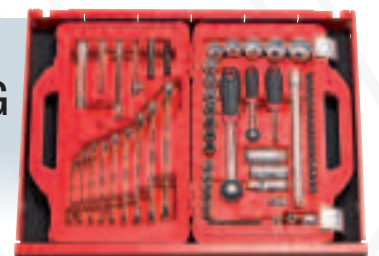

CLICK TORQUE BAR 811 LB PERFECT MATCH OF ACCURACY AND RESISTANCE

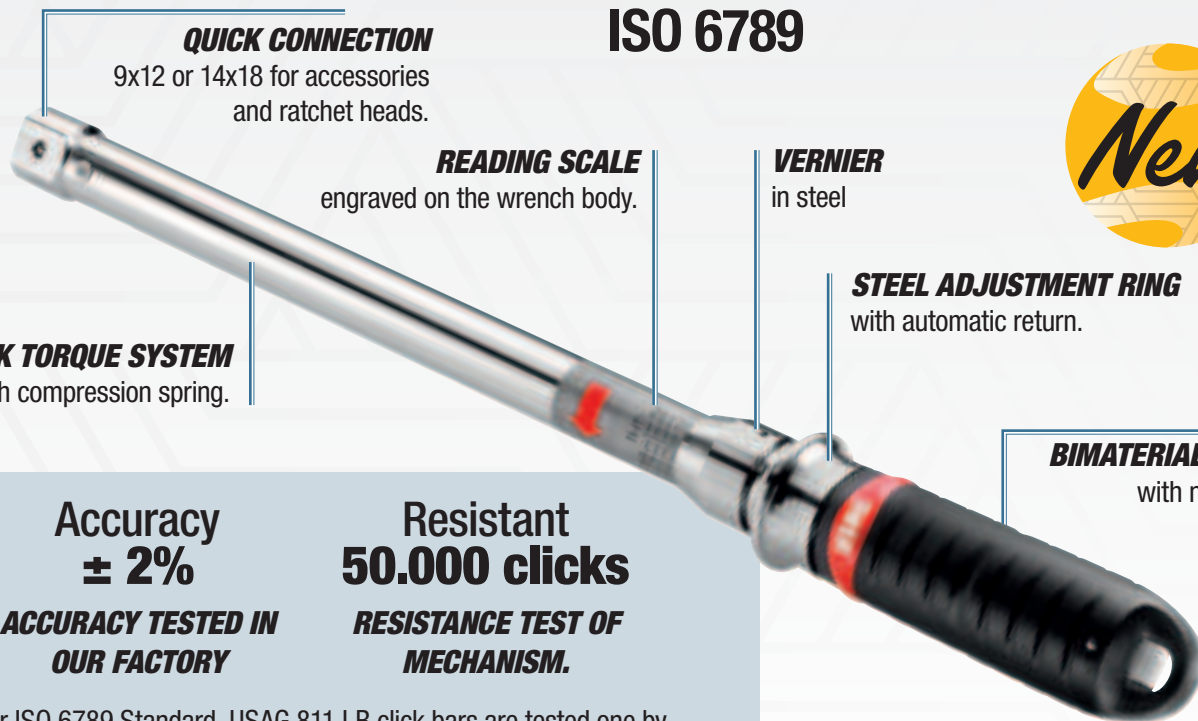

QUICK CONNECTION

9x12 or 14x18 for accessories and ratchet heads.

ISO 6789

READING SCALE

engraved on the wrench body.

VERNIER

in steel

STEEL ADJUSTMENT RING

with automatic return.

CLICK TORQUE SYSTEM

with compression spring.



BIMATERIAL HANDLE

with no-slip grip.

Accuracy
± 2%

ACCURACY TESTED IN
OUR FACTORY

Resistant
50.000 clicks

RESISTANCE TEST OF
MECHANISM.

As per ISO 6789 Standard, USAG 811 LB click bars are tested one by one in production, before being packaged. These bars can keep an accuracy between ±2% and ±4%, even after 5,000 tightenings.



YouTube



ACCURACY
±2%

811 LB

Click torque bar

ITEM	CODE	CAPACITY	□	L	RESOL.
811 LB 50	U08115021	10÷50 Nm	9x12 mm	357 mm	1 Nm
811 LB 100	U08115023	20÷100 Nm	9x12 mm	437 mm	1 Nm
811 LB 200	U08115024	40÷200 Nm	14x18 mm	515 mm	1 Nm
811 LB 350	U08115025	70÷350 Nm	14x18 mm	725 mm	2 Nm



Removable
ratchet



ACCURACY
±2%

3/8"

1/2"

811 LBE

Click torque wrench with removable ratchet

ITEM	CODE	CAPACITY	□	□	L	RESOL.
811 LBE 50	U08115026	10÷50 Nm	3/8"	9x12 mm	407 mm	1 Nm
811 LBE 100B	U08115027	20÷100 Nm	3/8"	9x12 mm	487 mm	1 Nm
811 LBE 100C	U08115028	20÷100 Nm	1/2"	9x12 mm	487 mm	1 Nm
811 LBE 200	U08115029	40÷200 Nm	1/2"	14x18 mm	565 mm	1 Nm
811 LBE 350	U08115032	70÷350 Nm	1/2"	14x18 mm	775 mm	2 Nm

TORQUE WRENCHES 810 SA - 811 SA WITH DIRECT READ SYSTEM.

REVERSIBLE RATCHET
with 72 theet mechanism.

ISO 6789



YouTube

CLICK TORQUE SYSTEM
with compression spring.

CONICAL HANDLE
in anti-slip bimaterial.

DIRECT READ
the value of the torque to apply is quickly visible.

QUICK TO ADJUST
you can set-up faster the torque needed.



810 SA

Direct read torque wrench with reversible ratchet

- Calibration certificate and REACH (SVHC) declaration included

ITEM	CODE	CAPACITY	<input checked="" type="checkbox"/>	L (mm)	RESOL.
810 SA 50	U08105002	10÷50 Nm	3/8"	350	0,25
810 SA 100	U08105003	20÷100 Nm	1/2"	410	0,5
810 SA 200	U08105005	40÷200 Nm	1/2"	475	1,0
810 SA 340	U08105006	60÷340 Nm	1/2"	630	1,0

ACCURACY
±4%

3/8"

1/2"

**CLOCKWISE
TIGHTENING**

811 SE

Direct read torque wrench with removable ratchet

- Calibration certificate and REACH (SVHC) declaration included

ITEM	CODE	CAPACITY	<input checked="" type="checkbox"/>	<input type="checkbox"/>	L (mm)	RESOL.
811 SE 50	U08115012	10÷50 Nm	3/8"	9x12	370	0,25
811 SE 100B	U08115013	20÷100 Nm	3/8"	9x12	430	0,5
811 SE 100C	U08115015	20÷100 Nm	1/2"	9x12	430	0,5
811 SE 200	U08115017	40÷200 Nm	1/2"	14x18	510	1,0
811 SE 340	U08115018	60÷340 Nm	1/2"	14x18	665	1,0

ACCURACY
±4%

3/8"

1/2"

**CLOCKWISE AND
COUNTERCLOCKWISE
TIGHTENING**

Removable
ratchet

**CLOCKWISE
TIGHTENING**



PRECISION
±4%

1/4"

**CLOCKWISE AND
COUNTERCLOCKWISE
TIGHTENING**

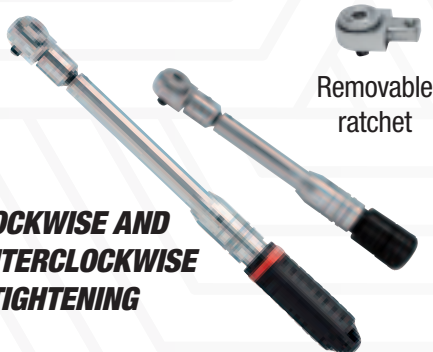

Removable
ratchet

PRECISION
±4%

1/4"

**CLOCKWISE AND
COUNTERCLOCKWISE
TIGHTENING**



PRECISION
±4%

3/4"

1/4

PRECISION
±6%



810 N

ISO 6789

Torque wrenches with reversible ratchet

- Sensible and audible alarm on reaching preset torque value
- Automatic resetting on pressure release after disengagement
- Supplied with test certificate

ITEM	CODE	CAPACITY	<input checked="" type="checkbox"/>	L	RESOL.
810 N 5	U08104000	1÷5 Nm	<input checked="" type="checkbox"/>	1/4" 197 mm	0,05
810 N 25	U08104001	5 ÷ 25 Nm	<input checked="" type="checkbox"/>	1/4" 290 mm	0,05

811 NE

ISO 6789

Torque wrenches with removable reversible ratchet

- Adjustable torque model for use in combination with fittings from the 811-series
- Sensible and audible alarm on reaching preset torque value
- Automatic resetting on pressure release after disengagement
- Supplied with test certificate

ITEM	CODE	CAPACITY	<input checked="" type="checkbox"/>	<input type="checkbox"/>	L	RESOL.
811 NE 5	U08114009	1÷5 Nm	<input checked="" type="checkbox"/>	<input type="checkbox"/>	1/4" 9x12 mm 185 mm	0,05
811 NE 25	U08114010	5÷25 Nm	<input checked="" type="checkbox"/>	<input type="checkbox"/>	1/4" 9x12 mm 300 mm	0,05

812 N

ISO 6789

Torque wrenches with reversible ratchet

- Adjustable torque model for clockwise and counterclockwise tightening by turning the ratchet 180°
- Accuracy ± 4% of the preset torque value
- Readings in Nm
- Sensible and audible alarm on reaching preset torque value
- Automatic resetting on pressure release after disengagement
- Safety block after setting torque
- Supplied in sheet steel box with test certificate

ITEM	CODE	CAPACITY	<input checked="" type="checkbox"/>	<input type="checkbox"/>
812 N 600	U08120006	120 ÷ 600 Nm	<input checked="" type="checkbox"/>	<input type="checkbox"/>
812 N 1000	U08120010	200 ÷ 1000 Nm	<input checked="" type="checkbox"/>	<input type="checkbox"/>

824 A

ISO 6789

Torque screwdrivers

- Adjustable torque model for clockwise tightening, for use in combination with bits from the 660 series or, using an adapter, with sockets from the 1/4" manual series
- Accuracy ± 6% of the preset torque value
- Readings in Nm
- Automatic disengagement on reaching the preset torque value
- Automatic resetting after 120°
- Supplied with regulation key and test certificate

CODE	CAPACITY	L	RESOL.
U08240004	0,5÷2,5 Nm	145 mm	0,1
U08240006	2÷10 Nm	167 mm	0,5

Controlled tightening using ratchets or T-wrenches

1/2"



YouTube

814 A

Torque-angle digital adapter

- Torque and angle tightening with digital precision using conventional tools
- For CW and CCW tightening
- Torque accuracy: $\pm 4\%$
- Angle accuracy: $\pm 2\%$
- Measuring mode: peak/track
- Measuring unit: Nm/ft.lb/in.lb/kgcm/degree
- Visible (LED) and audible (BUZZER) indicators when preset target value is reached
- 9 presettable target values
- 50 memory slots for measured values
- Supplied in ABS case with calibration certificates
- Power supply: 2 batteries AAA (included)

CODE	CAPACITY	RESOL.
U08140003	27 - 135	1/2" 0,1
U08140004	40 - 200	1/2" 0,1
U08140005	68 - 340	1/2" 0,1

PRECISION
 $\pm 2\%$

Correct measurement of the angle in any position



YouTube

831 A

U08310001

Digital angle meter

- Correct measurement of the angle in any position
- For CW and CCW tightening
- Accuracy: $\pm 2\%$
- Range: 0 - 360°
- Resolution: 0,1°
- Visible (LED) and audible (buzzer) indicators when preset target value is reached
- 9 presettable target values
- 50 memory slots for measured values
- Supplied in ABS case with calibration certificates
- Power supply: 2 batteries AAA (included)

Multiplication ratio

1:3,4

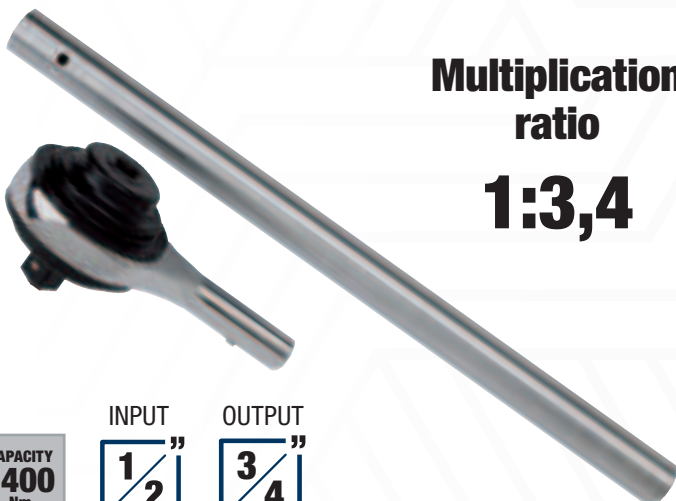

CAPACITY
1400
Nm

INPUT

1/2"

OUTPUT

3/4"

828 X4

U08280401

Torque multiplier

- Light compact model for use in maintenance of industrial vehicles, agricultural machinery and earth-moving equipment
- Supplied in nylon bag with safety lever and test certificate
- Transmission rate 4:1
- Max input torque: 400 Nm

Pullers



454

Outside pullers with two jaws

CODE	A	B	POWER	Hex
U04540000	65 mm	70 mm	1,5 t	13 mm
U04540010	90 mm	110 mm	3 t	17 mm
U04540020	130 mm	110 mm	3 t	17 mm
U04540030	175 mm	165 mm	4 t	17 mm
U04540040	220 mm	165 mm	4 t	17 mm
U04540050	270 mm	220 mm	5 t	21 mm
U04540060	340 mm	220 mm	5 t	21 mm

INCLUDED IN THE PRICE

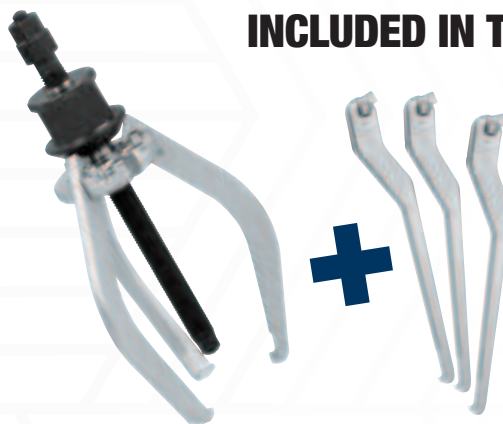

4
PIECES

451 N/S4

U04510100

Outside puller with three jaws

- Model with self-locking jaws
- Safety pin
- Working screw with 18 mm hexagonal drive
- Possibility of using with two jaws
- Carbon steel pressure screw
- Chrome Vanadium steel body
- Chrome plated and burnished finish
- Working screw M16x2
- Spare safety pins: U.306- 24J3

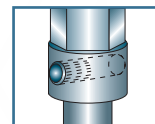

Safety pin increases working safety and preserves tool quality

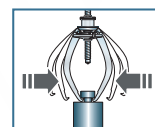

Self-locking self-centring



2-2,5-3-4-5-6-7-8 mm



YouTube

1/4 Bit-holding socket

9
PIECES

110
20
105
mm

COMPLETE KIT FOR DAMAGED SCREWS AND NUTS

20
PIECES

210
60
130
mm



458 S20

U04580312

Assortment of grip sockets and bits for damaged hexagonal screws and nuts

DESCRIPTION	ITEM/SIZE	PCS.
Pullers for damaged nuts and screws	458 B 8-10-11-12-13-14-15-16-17-18-19	11
Set of grip bits for damaged hexagonal screws	458 E 2-2,5-3-4-5-6-7-8	8
Bit-holder sockets	684 1/4	1

458 E/B9

U04580313

Set of grip bits for damaged hexagonal screws

DESCRIPTION	ITEM/SIZE	PCS.
Set of grip bits for damaged hexagonal screws	458 E 2-2,5-3-4-5-6-7-8	8
Bit holding socket	684 1/4	1



EXCLUSIVE PROFILE FOR HEXAGONAL SOCKET-HEAD SCREWS

The special design of the grip bits allows you to grip the hexagons recessed in any condition: intact or completely damaged.

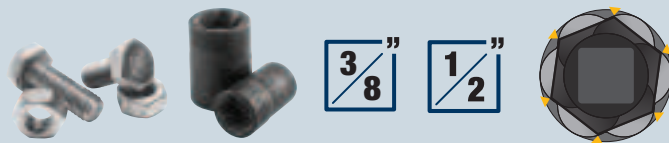

HELICOIDAL PROFILE FOR HEXAGONAL NUTS AND SCREWS

The conical helicoidal sockets guarantee an effective external grip on damaged hexagons.



ALUMINIUM

360°

995 AF
U09950006

Hand riveter with swivel head

- Ø 2,4 - 3,2 - 4 - 4,8 mm (3/32 - 1/8 - 5/32 - 3,16")
- 360° adjustable head
- Suitable for Aluminum rivets
- 4 interchangeable heads
- Light alloy body
- Plastic handles
- Metal clip for opening lock
- Supplied with head disassembly key



ALUMINIUM AND STEEL

995 A
U09950001

Hand riveter

- Steel: Ø 2,4 - 3,2 - 4 (3/32 - 1/8 - 5/32)
- Aluminium: Ø 2,4 - 3,2 - 4 - 4,8 mm (3/32 - 1/8 - 5/32 - 3,16")
- Light alloy body
- Pressed sheet steel pressure lever
- Handgrips with spring-action opening
- Supplied with three interchangeable nozzles and service key



-20% EFFORT

COMPACT AND POWERFUL

Only 330 mm long
20% less effort than the standard model



ALUMINIUM AND STEEL

995 LA
U09950004

Straight compact hand riveter

- Ø 2,4 - 3,2 - 4 - 4,8 - 6,4 mm (3/32 - 1/8 - 5/32 - 3,16 - 1/4")
- Compact model with the same capacity as a standard long riveter
- The internal lever system reduces operator effort
- Suitable for Aluminum and steel rivets
- 5 interchangeable heads
- Removable holder for spent nails
- Light alloy body
- Plastic handles



Ø
M4 - M5
M6 - M8

DELIVERED IN PLASTIC CASE

FOR BLIND-NUT RIVETS
(not included)

995 CA
U09950008

Hand riveter for blind-nut rivets

- Compact model with internal lever system that reduces operator effort
- Supplied with 4 interchangeable heads (M4-M5-M6-M8)
- To be used with aluminium and steel blind nuts (M4-M5-M6-M8) and stainless steel (M4-M5)
- Light alloy body
- Plastic handles
- Supplied in a plastic case (LxDxH: 320x175x50 mm) with blind nuts holders (not included)

SCISSORS 207 E STEEL STRENGTH.



YouTube



**THE ONLY ONE WITH INTEGRAL
STAINLESS STEEL STRUCTURE**

Flexural strength 180 Kg.

**BUILT-IN WIRE
STRIPPER**

**CABLE CUTTER ON
BOTH BLADES**

**MICRO ANTI-SLIP
TOOTHING**

207 E
U02070006

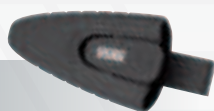

Professional scissors for electricians



1. Stripping
2. Crimping



Suitable for
multi-core cables.



SCISSORS 207 D THE REFERENCE FOR ELECTRICIANS.



**HANDLES RESISTANT
TO FLEXURAL
STRENGTH UP TO 80 KG**
glass-reinforced technopolymer.

50 mm²

FLUID AND STRONG BLADES
with micro tothing and cable cutter.

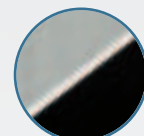

**OVERSIZED
HOLES**

207 D
U02070008

Scissors for electricians,
stainless steel blades



YouTube

SMART FUNCTION

Automatically selects AC/DC
voltage, resistance,
frequency

MAX
600 V

RMS



074 A
U00740001

SMART digital multimeter

- AC/DC measurement
- Resistance and continuity measurements (acoustic sound if circuit resistance is lower than 40 to Ω)
- Frequency measurements
- AC/DC current measurement with 076 P ammeter



CAT III 600V

TECHNICAL CHARACTERISTICS

Direct voltage DC	1÷600 mV÷V
Alternating voltage AC	1÷600 mV÷V
Resistance	0÷10 Ω ÷M Ω
Frequency	3÷40 kHz
Battery type (supplied)	2xAAA 1,5V



\varnothing 4÷28 mm²



YouTube

163

U01630001

Multi-purpose cable sheath stripper

- For circular and longitudinal stripping of cables with external sheathing in PVC
- Trigger system (-30% effort): necessary pressure 75N
- Roller for regulating cutting depth
- Self rolling stripping blade
- Trigger stop when blade is out
- Safety blade stop
- Ergonomic plastic body
- Spare blade included
- Kit of spare blades code 872272



007 MV
U00070035

Tool-holding pouch (empty)

- High strength fabric
- Velcro belt fixing
- Four stretch pockets for tools
- Hook for tape



007 MLV
U00070030

Tool-holding pouch with belt (empty)

- High strength fabric
- Six stretch pockets for tools
- Hook for tape
- Adjustable belt from 80 to 120 cm



**STAINLESS
STEEL BLADE**

210 mm

211 A

U02110001

Multi-purpose scissors

- Blade with micro anti-slip toothing
- Selection lever to adapt to small and big hands
- Security lever to block the blades
- Antislip bimaterial ergonomic handgrips



**STAINLESS
STEEL BLADE**

200 mm

211 B

U02110002

Multi-purpose scissors with inclined blades

- Blade with micro anti-slip toothing
- Selection lever to adapt to small and big hands
- Security lever to block the blades
- Antislip bimaterial ergonomic handgrips



**STAINLESS
STEEL BLADE**

280 mm

210 C

U02100003

Multi-purpose scissors

- Stainless steel blade with micro antislip toothing
- Big ergonomic bimaterial handles
- Perfect for Aluminium, cardboard, rubber, leather, moquette, etc.

**FOR
RIGHT-HANDERS**



**STAINLESS
STEEL BLADE**

190 mm

218 N

U02180002

Utility knife

- Stainless steel blade
- Safety blade blocking
- Easy opening pin
- Aluminium body with polyamide inserts
- Hanging hole and glass-cutter
- Supplied in nylon pouch with closing clip and belt loop

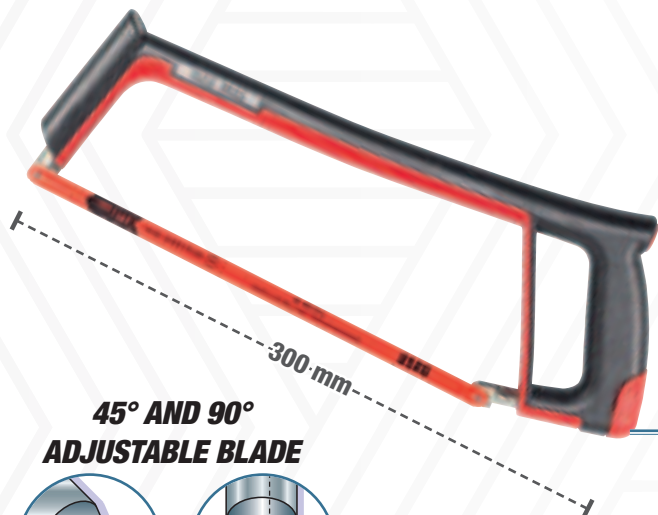

**45° AND 90°
ADJUSTABLE BLADE**

300 mm

200 S

U02000002

Hacksaw

- Steel body with anti-slip and shock resistant plastic coating
- Supplied with Cobalt blade 200 C24

BLADE TENSIONING SYSTEM

integrated into the handle

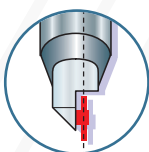
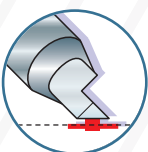

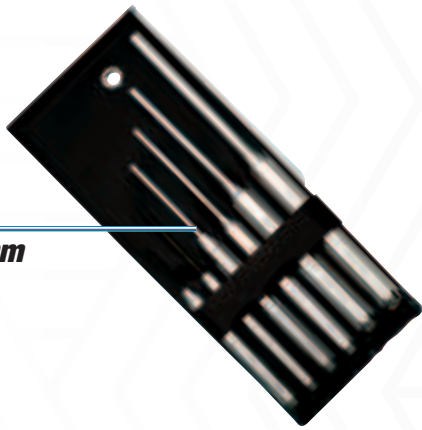

2-3-4-5-6-8 mm

6

PIECES

367 SE6

U03670081

Set of 6 pin punches

- 367/2x115-3x125-4x145-5x165-6x180-8x200 mm
- Supplied in plastic pouch
- Chrome Vanadium steel
- Inserted phosphatised tips for the 2 and 3 mm sizes



UNI 7784

376

Mallets

- Model with interchangeable plastic tips
- Carbon steel body
- Ash wood handle

CODE	Ø TIP	LENGTH
U03760001	22 mm	250 mm
U03760002	28 mm	275 mm
U03760003	35 mm	300 mm
U03760004	42 mm	325 mm
U03760005	50 mm	350 mm
U03760006	60 mm	380 mm



COMBINED MATERIALS FOR EXCELLENT RESULTS

- 1 Graphite core: maximum flexural strength.
- 2 High quality: Polypropylene body to absorb vibrations.
- 3 Rubber coating resistant to hydrocarbons.



DIN 1041

382 F

Hammers for mechanics with graphite handle

- German model with flat square surface and symmetric peen
- Graphite handle

CODE	HEAD	LENGTH
U03820102	200 g	285 mm
U03820103	300 g	300 mm
U03820105	500 g	310 mm
U03820107	800 g	350 mm
U03820108	1000 g	355 mm

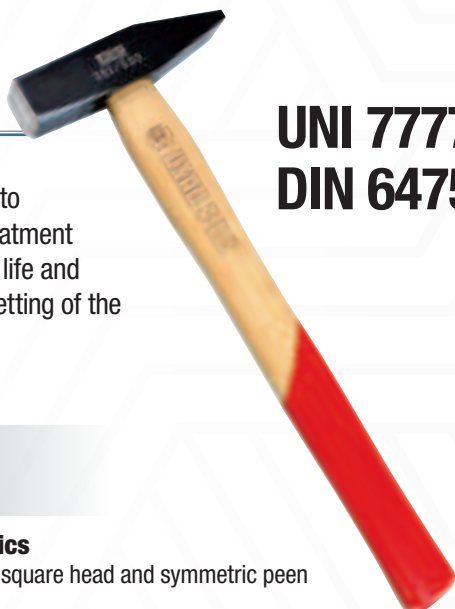

UNI 7777 DIN 6475

Head in Carbon steel forged and subjected to differentiated heat treatment to guarantee a longer life and avoid chipping or upsetting of the striking surface.

CODE	HEAD	LENGTH
U03820002	100 g	260 mm
U03820004	200 g	280 mm
U03820006	300 g	300 mm
U03820007	400 g	310 mm
U03820008	500 g	320 mm
U03820009	600 g	330 mm
U03820010	800 g	350 mm
U03820011	1000 g	360 mm
U03820013	1500 g	380 mm
U03820014	2000 g	400 mm

382

Hammers for mechanics

- German model with flat square head and symmetric peen
- Ash wood handle

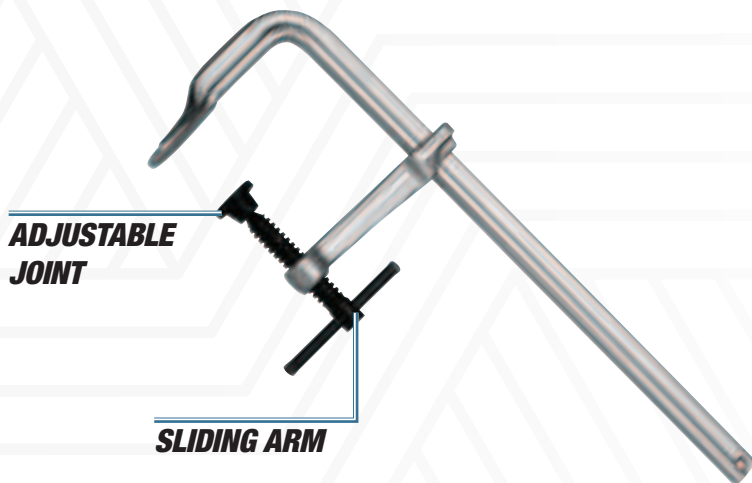

997 A

Screw-type clamp

- Body and sliding arm in forged steel

CODE	OPENING	SECTION	
U09970002	160 mm	16x7,5 mm	0,5 kg
U09970003	200 mm	19,5x9,5 mm	0,9 kg
U09970004	250 mm	22x10,5 mm	1,2 kg
U09970005	300 mm	25x12 mm	1,8 kg
U09970006	400 mm	25x12 mm	1,9 kg
U09970007	500 mm	25x12 mm	2,1 kg
U09970008	600 mm	25x12 mm	2,3 kg
U09970009	800 mm	27x13 mm	3,3 kg
U09970010	1000 mm	27x13 mm	3,7 kg

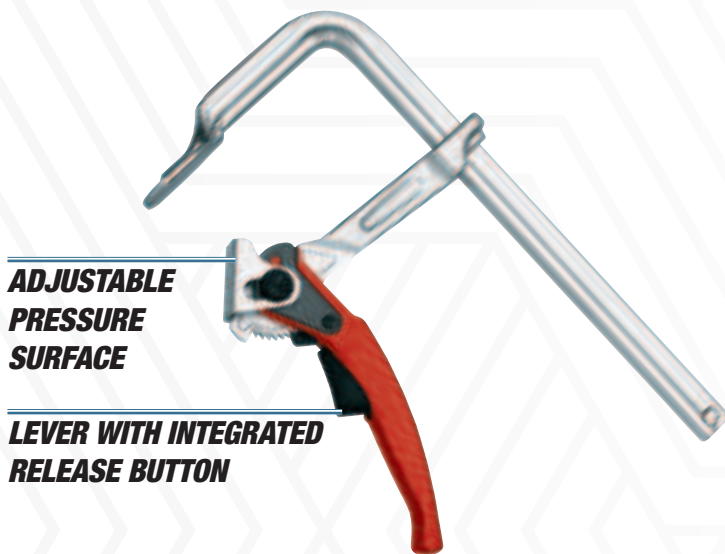

997 B

Lever-type clamp

- Quick lever model with precise regulation
- Body and sliding arm in forged steel
- Adjustable pressure cap

CODE	OPENING	SECTION	
U09970013	120 mm	13,5x6,5 mm	0,7 kg
U09970014	160 mm	16x7,5 mm	1 kg
U09970015	200 mm	19,5x9,5 mm	1,3 kg
U09970016	250 mm	22x10,5 mm	1,9 kg
U09970017	300 mm	25x12 mm	2,7 kg
U09970018	400 mm	25x12 mm	2,8 kg
U09970019	500 mm	25x12 mm	3 kg

10
PIECES



FOR RINGS WITH CAPACITY DIAMETERS FROM 20 TO 100 MM

Rings with holes on top

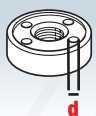

Rings with carvings on top



282 S10

U02820200

 2 kg |  mm |  330
↑ 60
↙ 215

Assortment in ABS case with pin wrenches for round and square ring nuts

- For rings with holes bored on the face
- The wrench is adjustable by turning the centre screw
- Removable pins
- Capacity: 20 to 100 mm
- Satin chrome finish
- High resistance ABS case with quick closing system
- Empty inner foam module: code U05191054Q

DESCRIPTION	SIZE	PCS.
Round pins	(d) 2,5 - 3 - 4 - 5 - 6 - 7 - 8 - 9 mm	4
Square pins	(a) 4 - 5 - 6 - 8 mm	4

DIN 338

HSS-G

14
PIECES



988 LA/S14

U09880070

Assortment with tap and drills

- Ø drills: 2,5-3,3-4,2-5,0-6,8-8,5-10,2
- M taps: 3x0,5-4x0,7-5x0,8-6x1-8x1,25-10x1,5-12x1,75

DIN 338

HSS-G

19
PIECES



988 MA/S19

U09880073

Assortment with drills

- Ø drills: 1,0-1,5-2,0-2,5-3,0-3,5-4,0-4,5-5,0-5,5-6,0-6,5-7,0-7,5-8,0-8,5-9,0-9,5-10,0

DIN 338

HSS-G

25
PIECES



988 MA/S25

U09880074

Assortment with drills

- Ø drills: 1,0-1,5-2,0-2,5-3,0-3,5-4,0-4,5-5,0-5,5-6,0-6,5-7,0-7,5-8,0-8,5-9,0-9,5-10,0-10,5-11,0-11,5-12,0-12,5-13,0



HSS

3
PIECES



988 D/S3

U09880020

Set in sheet steel case

ITEM	Ø STEPS	Ø SHAFT	LENGTH
988 D1	4-5-6-7-8-9-10-11-12 mm	6 mm	65 mm
988 D2	4-6-8-10-12-14-16-18-20 mm	8 mm	75 mm
988 D3	4-6-8-10-12-14-16-18-20-22-24-26-28-30 mm	10 mm	100 mm

HSS

12
PIECES



988 G/S12

U09880100

Set of 10 bimetallic hole saws

- 10 pcs 988 G (Ø 19-22-25-29-35-38-44-51-57-64)
- Cutting depth Max 38 mm

HSS

10
PIECES



Ø 6 mm



988 E/S10

U09880062

Set of ten rotary burrs in hard metal

- 8 pcs. (Ø 10 and 12 shapes EA-EC-EF-EG)
- 2 pcs (Ø 12 shapes ED-EM)

New



YouTube



Adjustable hooks



SMD LED



COB LED



1 = 18 h
2 = 3,6 h
3 = 1,8 h



Li-ion

RECHARGEABLE



USB

889 RL
U08890036

LED inspection lamp

DUAL USE



45 LUMEN

LAMP



MAX 420 LUMEN

TORCH

2 brightness levels
(120 and 420 lumen)

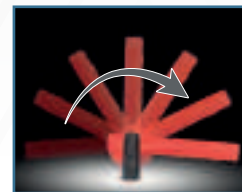

Magnetic base
adjustable up to 180°



4 LED battery
indicator



YouTube



New



SMD LED



COB LED



1 = 3 h
2 = 10 h
3 = 35 h



Li-ion

RECHARGEABLE



USB

889 IL
U08890046

Articulated LED inspection lamp

TRIPLE FUNCTION



50 LUMEN

HEAD



400 LUMEN

TORCH



150 LUMEN

FRONTAL

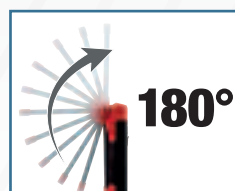

Jointed and 180°
adjustable



4 LED battery
indicator



Magnetic base and
hook clamp



YouTube

**MOTION DETECTION
SENSOR**



**Just 91 mm
length**



SMD
LED



IP54



1 = 18 h
2 = 3,6 h
3 = 1,8 h



Li-ion

RECHARGEABLE



889 GR
U08890044

LED compact spotlight

3 BRIGHTNESS LEVELS



50, 250 and 500 lumen with a simple touch



Magnetic base
adjustable up to 90°



Adjustable hook
up to 360°



Fluorescent
reflector



COB
LED



IP67



2,5 h



1 = 8 h
2 = 4 h
3 = 2,5 h



IK07



Li-ion

889 RT
U08890038

Rechargeable LED spotlight - certified IP67

3 BRIGHTNESS LEVELS



500, 1000 and 1500 lumen with a simple touch



YouTube

Magnetic
base



180°



**WORKS WITH
OR WITHOUT CABLE**

5 meters cable included



360°

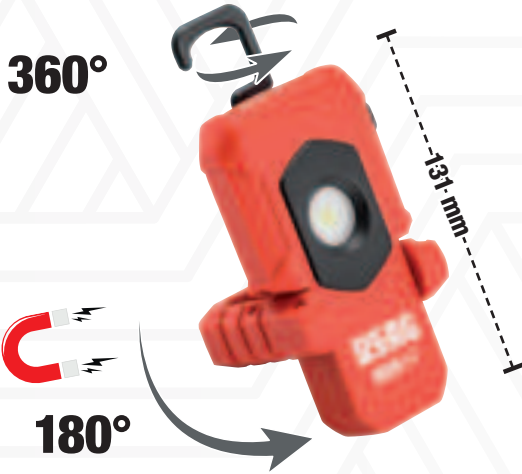

Lamp
COB LED

Torch
SMD LED

IP20

Li-ion

USB

889 RP
U08890045

Compact LED rechargeable inspection lamp



YouTube

DUAL USE



Lamp



Torch

New



Lamp
COB LED

Torch
SMD LED

IP67

Li-ion

USB

889 TRE
U08890018

Rechargeable LED torch - dual use

DUAL USE



Lamp



Torch

Adjustable hanging clip with magnets



COB LED

IP54

3xAAA

889 LTE
U08890014

Frontal LED lamp



NON-SLIP STRAP

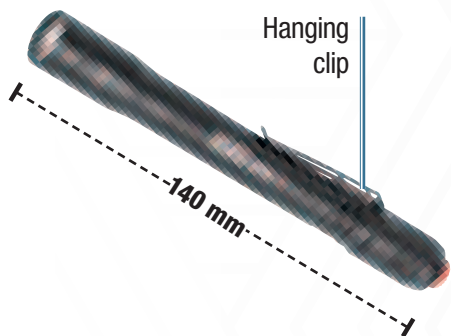

- SMD LED
- IP54
- 2xAAA

889 TS
U08890070

Pen-type LED torch in Aluminium - 110 Lumen

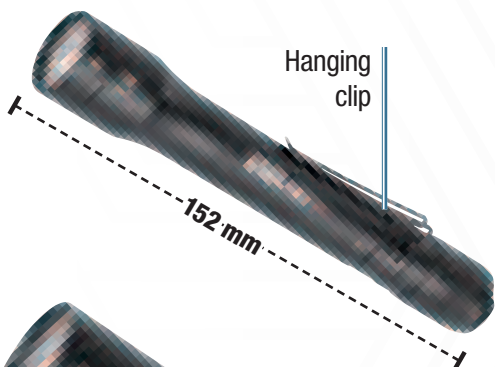

- SMD LED
- IP54
- 2xAAA

889 TM
U08890071

Pen-type LED torch in Aluminium - 170 Lumen

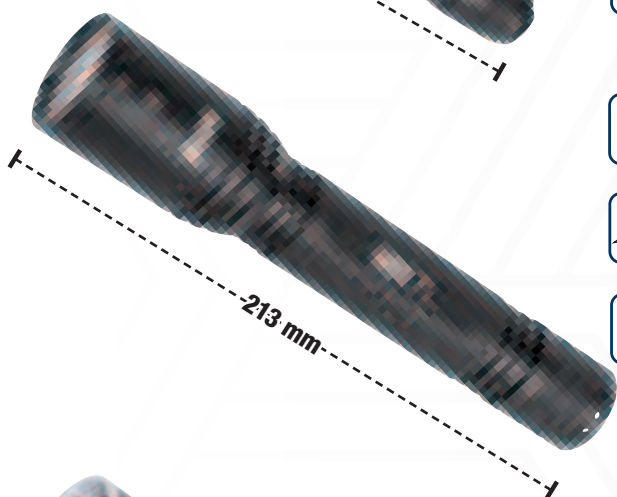

- SMD LED
- IP54
- 3xC

889 TL
U08890072

LED torch in Aluminium - 680 Lumen



- SMD LED
- IP54
- Li-ion

889 TR
U08890073

Rechargeable LED torch in Aluminium - 600 Lumen

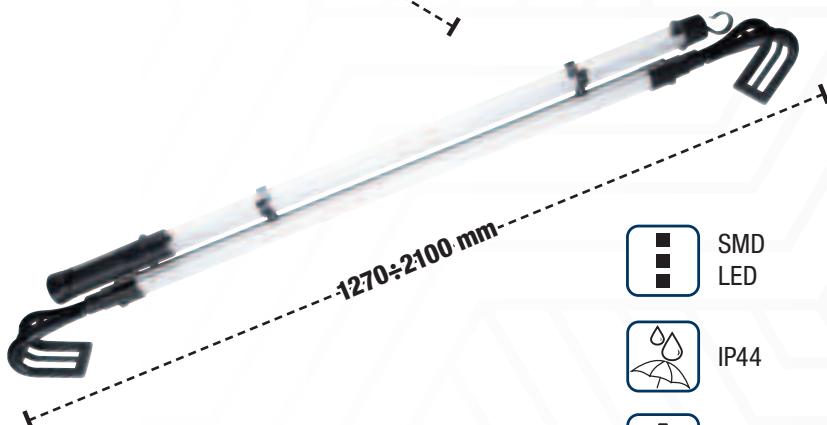

- SMD LED
- IP44
- Li-ion

889 UB
U08890034

Rechargeable under bonnet LED inspection lamp



INTEGRATED TRANSFORMER

No external power supply.



YouTube

12 V 1200 A

10 kg 400 mm 320 115



REAR CONNECTOR FOR VOLTAGE SELECTION



12 V 24 V 1400 A 700 A

20,8 kg 560 mm 200 590



12V - 3700 A

1613 RA12

U16130019

3500 A

Professional start booster 12 V, portable

- Shockproof ABS shell
- Also suitable for sealed batteries

Cable length
155 cm

1613 AGM12-24

U16130013

24V - 1860 A

Professional start booster 12-24 V, portable

- Shockproof ABS shell
- Overvoltage protection

Cable length
155 cm



YouTube

COMPRESSION POWER

735 kg (6 bar), 1226 kg (10 bar).

447 T

U04470101

Universal pneumatic shock absorber dismantler

- Ideal for cars
- Supplied with lower brackets 447 TC1 (78÷130 mm) and 447 TC2 (105÷182 mm), vice 447 TA and universal upper clamps 447 TB1

TECHNICAL CHARACTERISTICS

Compression power	735 kg (6 bar) - 1226 kg (10 bar)
Recommended air pressure	6÷10 bar
Piston stroke	420 mm
Cylinder	Aluminium alloy and nylon resin

60 kg 470 mm 1.390 450

Adjustable pressure up to 4 BAR

12 V

10 Litres

2847/3

U28470084

Brake bleeder

- For changing, filling and bleeding the circuit of brakes on cars and industrial vehicles
- Device designed exclusively for brake fluids DOT 3, DOT 4, DOT 5.1. No LHM.

TECHNICAL CHARACTERISTICS

Operating liquid system	Peristaltic pump (no direct/liquid contact, no air pressure on liquid)
Power supply	12 V (alligators clips)
Tank capacity	10 liters
Pressure limiting device	4 bar
Elastic spiral hose	4 m (elastic)
Power cable	4 m



Supplied with:

- spare gaskets
- 1 multi-diameter cap 44-45-46 mm (2847 N11)
- 1 tank for oil recovery.

FOR 6÷12 V BATTERIES

Also for
Start & Stop



YouTube



Compatible with
thermocouple K



890 K

U08901000

Digital battery tester with printer

1651

U16510001

Digital infrared thermometer

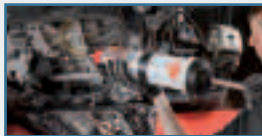

IDEAL TO DROP OIL INTO THE CAR DIFFERENTIAL

Not suitable for fuels and mineral oils

1,5
Litres



421 P

U04210020

Suction gun

IDEAL FOR SUCTION AND DISPENSING OF OIL, ANTIFREEZE, POWER STEERING OIL



421 M

U04210021

Suction gun



3
Litres

IDEAL TO DROP OIL INTO THE CAR DIFFERENTIAL

Working pressure
6÷10 bar



2847 A

U28470086

Vacuum brake bleeder

9,5
Litres



4,1 kg | 230 mm | 627 | 302



1785 B

U17850005

Fluid extractor

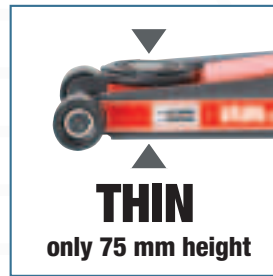

3
TON

30,5
kg



3t



2550 A

U25500001

Hydraulic service jack 3t for cars and commercial vehicles

- Steel structure
- High capacity for use on cars, SUVs and vans
- Dual pump system to lift the car faster
- Equipped with manual descent control
- Air bleed valve, to avoid risk of over-load

2550 B

U25500002

Hydraulic service jack 2t

- Steel structure
- Versatile and compact for use in narrow spaces
- Dual pump system to lift the car faster
- Equipped with lifting pedal
- Equipped with manual descent control
- Air bleed valve, to avoid risk of over-load

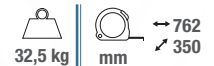

2
TON

32,5
kg



2t

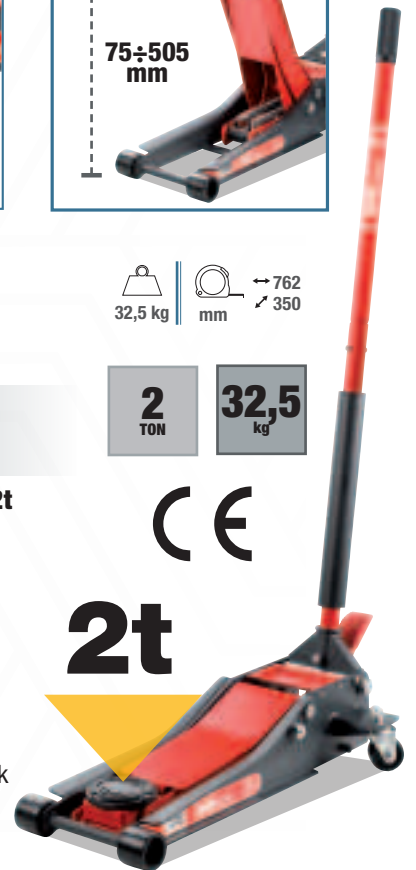

1950 C

Pair of jack stands

- Adjustable height with toothed mechanism and lever release
- Locking pin with chain
- 1950 C/3: model adjustable in 10 positions
- 1950 C/6: model adjustable in 13 positions



2
PIECES

WHEEL LOCKING NUTS AND SCREWS REMOVER KIT

YouTube
TUTORIAL VIDEO



10
PIECES

272 DS

U02720001

Kit to extract nuts and screws from alloy wheels

- Does not damage the alloy rim
- Special tungsten carbide drills capable of drilling any type of material (lubricate with cutting oil at each use)
- Super thin conical sockets to center/extract on any type of alloy wheel



CODE	CAPACITY	H MAX	H MIN	DIMENSIONS	W
U19501001	3 t	427 mm	300 mm	207x188 mm	7 kg
U19501002	6 t	620 mm	400 mm	285x250 mm	14 kg



3
PIECES

1 1/2"

270 C/C3
U02700106

Assortment with hexagonal impact sockets for tyre rims with teflon protection in modular box

17 **19** **21**

↔ 190
↑ 58
mm ↘ 144

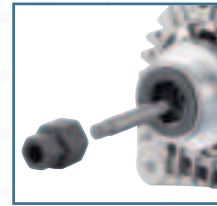

22
PIECES

1881 S22
U18810082

Set of 22 wrenches for assembling and disassembling the nuts of alternators pulleys
• Supplied in a plastic case



9
PIECES

Two wire brushes
Ø 20mm and 25mm



885 F
U08850004

Injector cleaning kit

- Ideal for duct cleaning of injectors mounted on common rail engines

6
PIECES

1 1/2"

884 C/S6
U08841000

Set of six wrenches for injector pipes fittings

- For assembly and disassembly of injectors pipes fittings
- Length: 98 mm
- Sizes: 12-14-16-17-18-19 mm



**POSSIBILITY TO STORE
IT INSIDE OUR ROLLER
CABINET DRAWERS**

Carrying handle

↔ 475
↑ 50
mm ↘ 290
230 g

2000 G
U20000110

Kneeling pad



4,6 kg | ↔ 1.030
mm | ↑ 480
↘ 115

2000 A
U20000100

Inspection creeper

- Headrest in vinyl resistant to hydrocarbons, padded with high resistance foam rubber
- Plastic body resistant to hydrocarbons, washable



FAST OIL-FILTER WRENCH 443 N AUTOMATIC BELT CLAMPING.



YouTube

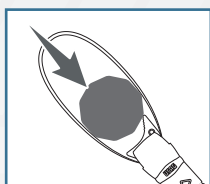

**AUTOMATIC
BELT CLAMPING**

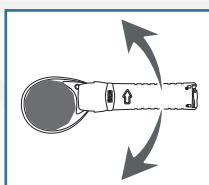

RATCHET EFFECT

Working rapidly. Possibility to work in narrow spaces.

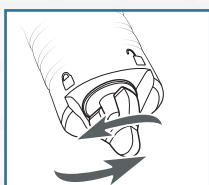

**LEVER TO INCREASE
CLAMPING POWER**



443 N
U04430005

**Fast oil-filter wrench
(cars)**



**66÷105
mm**

443 NC
U04430007

**Fast oil-filter wrench
(industrial vehicles)**



**106÷150
mm**

**6
PIECES**

3/8"

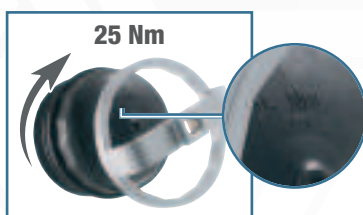
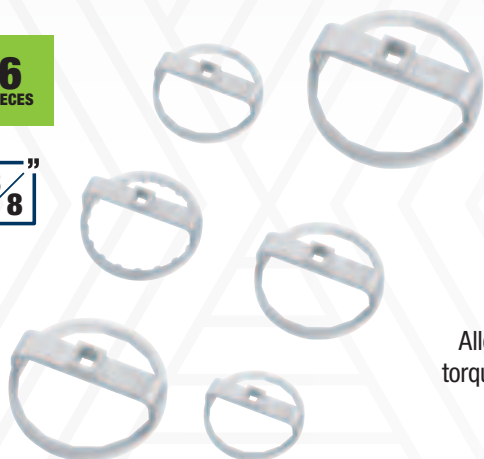

Allows the re-tightening at the original torque (value indicated on the plastic cap)

446 DA/SE6
U04461104

Set of 6 cup wrenches for oil filters

- 3/8" square drive
- Steel body
- Set for Fiat, Lancia, Alfa Romeo, BMW, Renault, Volkswagen, Skoda, Audi, Seat, Mercedes
- Profile dimensions: Ø 74 mm x 14 sides - Ø 75 mm x 16 sides - Ø 86 mm x 16 sides - Ø 102 mm x 14 sides - Ø 66 mm x 18 sides - Ø 96 mm x 18 sides



Frame the QR code and download the list of applications or go to usag-tools.net

446 S28
U04461204

Set of 30 oil-filter cap wrenches

- Sizes of the oil-filter cap wrenches (Ø x N ° sides): 66/6 - 65/14 - 65/67 - 68/14 - 73/14 - 74/15 - 74/76 - 75/77 - 76/12 - 76/14 - 76/30 - 76/8 - 78/15 - 80/15 - 80/82 - 86/16 - 86/18 - 90/15 - 92/10 - 93/15 - 93/36 - 93/45 - 95/15 - 96/18 - 100/15 - 106/15 - 108/15 - 108/18

3/8"

1/2"

**30
PIECES**

7 kg | 620 mm | 70 mm | 500

Frame the QR code and download the list of applications or go to usag-tools.net



IN ALUMINIUM

446 DT/S2

U04461203

Set of two cap wrenches for oil filter covers - Japanese cars

- Reduces the risk of damage to the oil filter covers
- Can also be used for tightening with a torque wrench



2
PIECES

Frame the QR code and download the list of applications or go to usag-tools.net



263/S16

U02631400

Oil draining kit

- Magnetic sockets to hold plugs
- 1 hinged wrench 3/8"
- 2 bits \square 8-10 mm 3/8"
- 6 bits \circ 8-10-12-13-14-17 mm 3/8"
- 6 hexagonal sockets \blacklozenge 13-14-17-18-19-21 mm 3/8"
- 1 TORX® bit \star T45

Connection for oil collector

16
PIECES

3/8"



Integrated oil collection tray

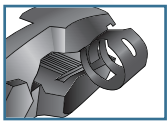

2 in 1

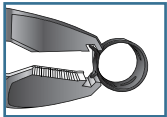

871 D

U08710001



Pliers for CORBIN clamps

- Model with frontal or side hooking
- Jaws with serrated gripping surface



870 C

U08700006

Pliers for fuel hoses

- For petrol and diesel vehicles
- Ergonomic bimaterial handgrip

3 working positions



871 C

U08719005P

CLICK spring-clips pliers

- Three-axial heads to work in any position
- To open and close CLICK spring-clips on fuel circuits, intake manifolds and hydraulic circuits

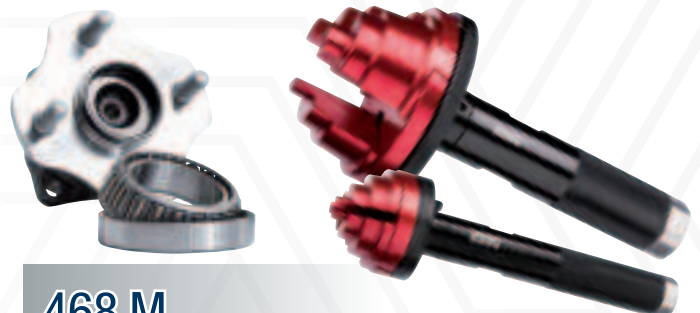

468 M

Bearings and seals drivers

- It simplifies the insertion of external rings for angular ball bearings
- Axis, bearing seat and sealing rings are not damaged
- Adjustable ring in 3 positions
- Steel handle
- It can be used on most vehicles, including motorcycles

CODE	CAPACITY	LENGTH
U04680150	9,5÷50 mm	176 mm
U04680151	18÷90 mm	210 mm



2 MODES:

- 1 250 l/min - 50°÷400°C
- 2 500 l/min - 50°÷600°C

MAX
600°

2000
WATT

391
U03910001

Digital heat gun

- Model with electronic checking of temperature and air volume by digital display
- Possibility to set programs: 2 heating modes and 2 air flows selectable
- Equipped with a cooling system

Accessories included



TECHNICAL CHARACTERISTICS

Suction cup threaded connection	M18
Sound level	78 Db
Total length	610 mm
Weight	4 Kg
Recommended air pressure	6,2 bar
Air inlet	1/4"

400 P
U04000010

Pneumatic dent puller

- Ideal to remove dents without the need to repaint
- Supplied with 3 suction cups (Ø 75-100-125 mm), in a plastic case with transport handle and closure clip
- Spare part kit with 3 suction cups: code 1004735-98

5
PIECES

To extract mouldings, fasteners, trim clips from door panels and dashboards



426 B/S5
U04260006

Set of 5 tools for plastic elements

4
PIECES

For removal of counterweights, silicone, mouldings etc.



426 C/S4
U04260007

Set of 4 multi-purpose plastic scrapers

4
PIECES

To separate timing belt cover, cylinder head engine, drive belt etc.



426 D/S4
U04260005

Set of 4 plastic separator scrapers

2
PIECES

115 CL/SE2
U01150022

Double-joint pliers with half-round jaws

- Ideal for gripping pieces and parts difficult to reach

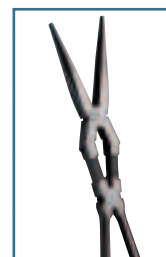
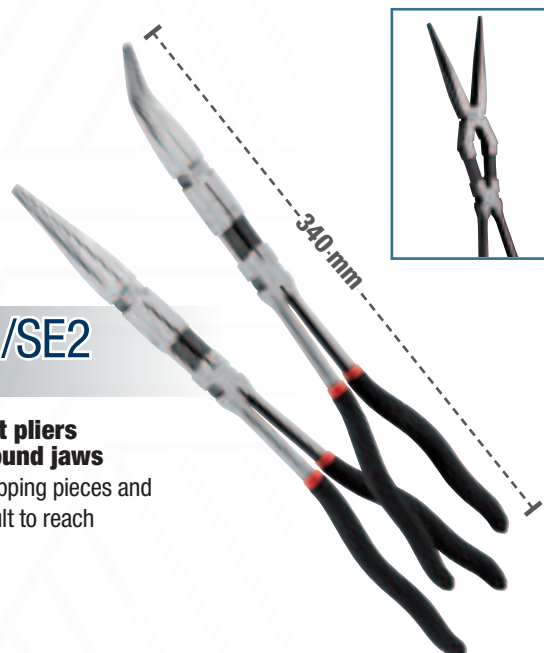

TRUCK PRODUCT SELECTION

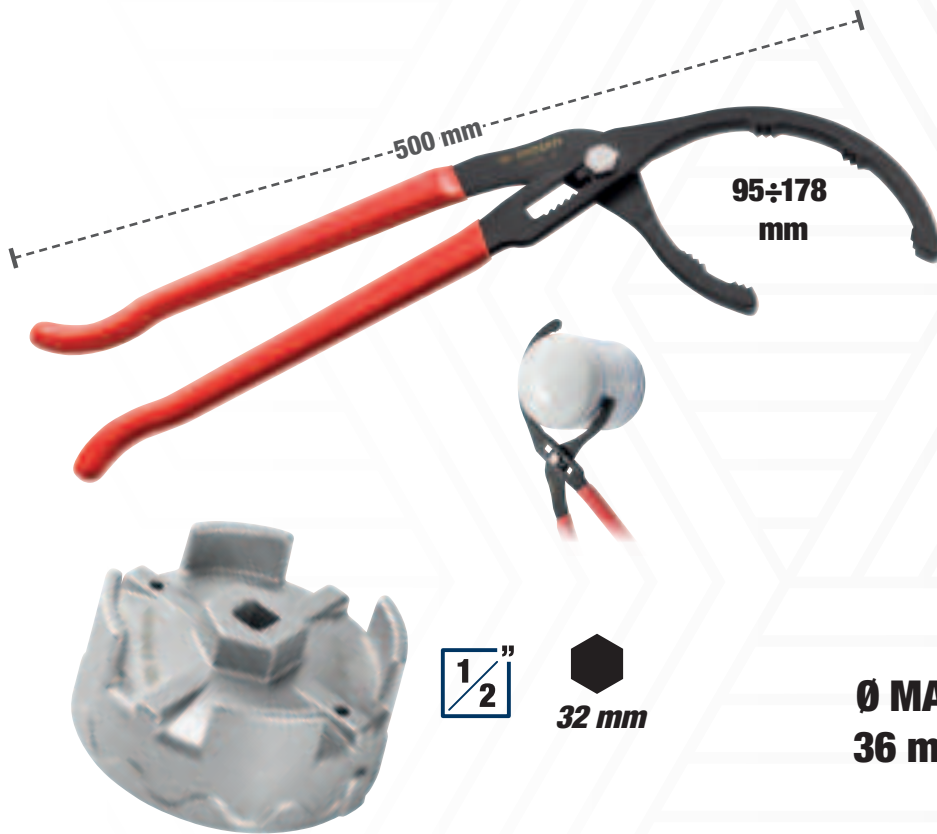

445 B

U04450015

Oil-filter wrench - big diameters

- 8-position model
- Jaws with "triangle" teeth for enhanced filter tightening
- Steel body
- Handles sheathed in PVC
- Sandblasted enamelled finish
- Burnished finish

1/2"

32 mm

**Ø MAX
36 mm**

36 mm



446 RT

U04461206

Cap wrench for oil filters TRUCK

- Specific for removing the oil filters of RENAULT and VOLVO trucks
- Body in Aluminum



Profile dimensions
Ø106 mm x 15 sides

449 IDA

U04490019

Ball joints separator

- Mechanical screw model
- For extracting ball-joints from steering wheel and suspensions on industrial vehicles

22 mm

**Ø MAX
23 mm**



22 mm

**Ø MAX
25 mm**



3/4"

**Ø MAX
42 mm**



449 TA

U04490010

Ball-joint extractors for industrial vehicles

- For removing steering and suspension ball-joints

449 TB

U04490015

Ball-joint extractors for industrial vehicles

- For removing steering and suspension ball-joints

449 TC

U04490021

Ball-joint extractors for industrial vehicles

- For removing steering and suspension ball-joints

LED LIGHTING

1/2"

1.898 Nm 2,2 kg



YouTube

MAGNESIUM ALLOY CASING



THE TOP OF THE RANGE

943 PC1 1/2"

U09430001

Magnesium impact wrench with LED - the top

TECHNICAL CHARACTERISTICS		TECHNICAL CHARACTERISTICS	
Square drive	1/2"	Recommended air pressure	6,2 bar
Bolt capacity	M20	Sound level	94 ±3 dB(A)
Max torque	1.898 Nm	Sound power	105 ±3 dB(A)
Torque in use (Nm min-Max)	320÷460 Nm	Vibrations	6,4 m/s ²
Strokes per minute	1200	Air inlet	1/4"
Free speed	6.500 rpm	Ø internal hose	10 mm
Average air consumption	172 l/min	Weight	2,2 kg

MAGNESIUM ALLOY CASING

1/2"

1.600 Nm 2 kg



YouTube



THE REFERENCE MODEL

929 PC1 1/2"

U09290001

Magnesium impact wrench

TECHNICAL CHARACTERISTICS		TECHNICAL CHARACTERISTICS	
Square drive	1/2"	Recommended air pressure	6,2 bar
Bolt capacity	M16	Sound level	93 ±3 dB(A)
Max torque	1.600 Nm	Sound power	104 ±3 dB(A)
Torque in use (Nm min-Max)	280÷440 Nm	Vibrations	6,2 m/s ²
Strokes per minute	1.300	Air inlet	1/4"
Free speed	7.000 rpm	Ø internal hose	10 mm
Average air consumption	172 l/min	Weight	2,0 kg

EXTRA-COMPACT



1/2"

861 Nm 1,3 kg



YouTube

942 PC3 1/2"

U09420012

Extra-compact impact wrench

TECHNICAL CHARACTERISTICS		TECHNICAL CHARACTERISTICS	
Square drive	1/2"	Recommended air pressure	6,2 bar
Bolt capacity	M16	Sound level	91,1±3 dB(A)
Max torque	861 Nm	Sound power	108,1±3 dB(A)
Torque in use (Nm min-Max)	150÷220 Nm	Vibrations	9,57 m/s ²
Strokes per minute	1650	Air inlet	1/4"
Free speed	10.000 rpm	Ø internal hose	10 mm
Average air consumption	127 l/min	Weight	1,3 kg

YouTube



Modular with the drawers of USAG roller cabinets

943 PC1/C12

U09430005

↔ 415
↓ 92
mm ↗ 283

1/2"

12
PIECES



Assortment with hexagonal sockets and impact wrench in modular box

DESCRIPTION	ITEM/SIZE	PCS.
Magnesium impact wrench with LED - the top	943 PC1 1/2	1
Impact hexagonal sockets	235 1/2 M/ 10-13-17-18-19-22-24-27-30-32 mm	10
Lock pins	235 MCA/4-6	2
Safety rings	235 MDA/4-6	2
Impact extensions	236 1/2 M/125	1



Modular with the drawers of USAG roller cabinets

929 PC1/C12

U09290005

↔ 415
↓ 92
mm ↗ 283

1/2"

12
PIECES



Assortment with hexagonal sockets and impact wrench in modular box

DESCRIPTION	ITEM/SIZE	PCS.
Magnesium impact wrench	929 PC1 1/2	1
Impact hexagonal sockets	235 1/2 M/ 10-13-17-18-19-22-24-27-30-32 mm	10
Lock pins	235 MCA/4-6	2
Safety rings	235 MDA/4-6	2
Impact extensions	236 1/2 M/125	1



Modular with the drawers of USAG roller cabinets

942 PC3/C7

U09420015

↔ 375
↓ 80
mm ↗ 186

1/2"

7
PIECES



Assortment with hexagonal sockets and impact wrench in modular box

DESCRIPTION	ITEM/SIZE	PCS.
Extra-compact impact wrench	942 PC3 1/2	1
Impact hexagonal sockets	235 1/2 M/ 13-17-19-21-22-24 mm	6
Lock pins	235 MCA/4	1
Safety rings	235 MDA/4	1

LED LIGHTING

MAGNESIUM ALLOY CASING

ALUMINIUM BODY

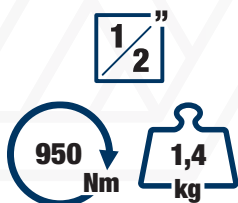

943 PC2 1/2"

U09430002

Magnesium impact wrench with LED - extra compact

TECHNICAL CHARACTERISTICS	
Square drive	1/2"
Bolt capacity	M16
Max torque	950 Nm
Torque in use (Nm min-Max)	200÷270 Nm
Strokes per minute	1400
Free speed	10.000 rpm
Average air consumption	167 l/min

TECHNICAL CHARACTERISTICS	
Recommended air pressure	6,2 bar
Sound level	95±3 dB(A)
Sound power	107±3 dB(A)
Vibrations	3,9 m/s ²
Air inlet	1/4"
Ø internal hose	10 mm
Weight	1,4 kg

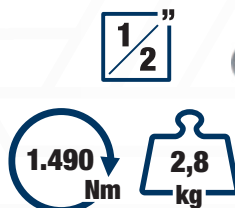

928 AC1 1/2"

U09280014

Aluminium impact wrench

TECHNICAL CHARACTERISTICS	
Square drive	1/2"
Bolt capacity	M16
Max torque	1.490 Nm
Torque in use (Nm min-Max)	135÷380 Nm
Strokes per minute	1.120
Free speed	6.500 rpm
Average air consumption	147 l/min
Recommended air pressure	6,2 bar

TECHNICAL CHARACTERISTICS	
Sound level	90 ±3 dB(A)
Sound power	101 ±3 dB(A)
Vibrations	5,2 m/s ²
Air inlet	1/4"
Ø internal hose	10 mm
Weight	2,8 kg

TITANIUM ALLOY CASING

ALUMINIUM BODY

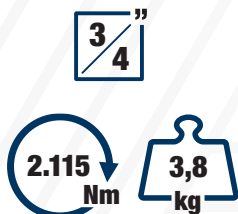

942 PD1 3/4"

U09420004

Impact wrench (Titanium structure)

TECHNICAL CHARACTERISTICS	
Square drive	3/4"
Bolt capacity	M27
Max torque	2.115 Nm
Torque in use (Nm min-Max)	500÷800 Nm
Strokes per minute	950
Free speed	5.300 rpm
Average air consumption	200 l/min

TECHNICAL CHARACTERISTICS	
Recommended air pressure	6,2 bar
Sound level	97,8±3 dB(A)
Sound power	108,8±3 dB(A)
Vibrations	5,06 m/s ²
Air inlet	3/8"
Ø internal hose	10 mm
Weight	3,8 kg

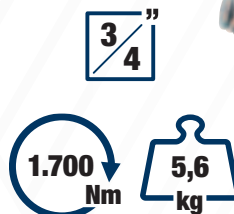

928 D1 3/4"

U09280015

Aluminium impact wrench

TECHNICAL CHARACTERISTICS	
Square drive	3/4"
Bolt capacity	M24
Max torque	1.700 Nm
Torque in use (Nm min-Max)	500÷1.050 Nm
Strokes per minute	790
Free speed	5.700 rpm
Average air consumption	193 l/min

TECHNICAL CHARACTERISTICS	
Recommended air pressure	6,2 bar
Sound level	98,4±3 dB(A)
Sound power	109,4±3 dB(A)
Vibrations	9,1 m/s ²
Air inlet	3/8"
Ø internal hose	13 mm
Weight	5,6 kg

COMPOSITE MATERIAL FRAME

SOFT-TOUCH BIMATERIAL GRIP



942 PE1 1"

U09420005

Impact wrench (composite material frame)

TECHNICAL CHARACTERISTICS		TECHNICAL CHARACTERISTICS	
Square drive	1"	Recommended air pressure	6,2 bar
Bolt capacity	M38	Sound level	100,9 ±3 dB(A)
Max torque	3.390 Nm	Sound power	111,9 ±3 dB(A)
Torque in use (Nm min-Max)	203÷1.627 Nm	Vibrations	10,6 m/s ²
Strokes per minute	900	Air inlet	1/2"
Free speed	5.000 rpm	Ø internal hose	19 mm
Average air consumption	400 l/min	Weight	6,8 kg

COMPOSITE MATERIAL FRAME

SOFT-TOUCH BIMATERIAL GRIP



942 PEL2 1"

U09420007

Reversible straight impact wrench with long anvil (composite material frame)

TECHNICAL CHARACTERISTICS		TECHNICAL CHARACTERISTICS	
Square drive	1"	Recommended air pressure	6,2 bar
Bolt capacity	M38	Sound level	105 ±3 dB(A)
Max torque	3.390 Nm	Sound power	116 ±3 dB(A)
Torque in use (Nm min-Max)	203÷1.627 Nm	Vibrations	15,6 m/s ²
Strokes per minute	1000	Air inlet	1/2"
Free speed	5.000 rpm	Ø internal hose	19 mm
Average air consumption	480 l/min	Weight	9 kg

ALUMINIUM BODY

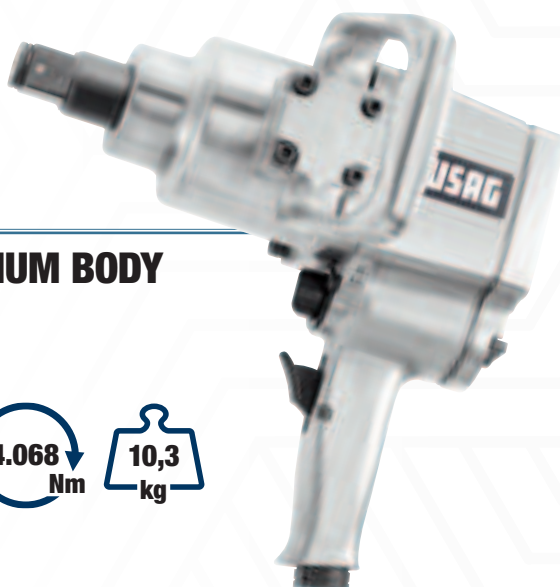
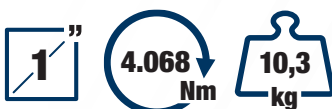

910 E1 1"

U09100020

Aluminium impact wrench

TECHNICAL CHARACTERISTICS		TECHNICAL CHARACTERISTICS	
Square drive	1"	Recommended air pressure	6,2 bar
Bolt capacity	M33	Sound level	102 ±3 dB(A)
Max torque	4.068 Nm	Sound power	113 ±3 dB(A)
Torque in use (Nm min-Max)	850÷1.300 Nm	Vibrations	15,2 m/s ²
Strokes per minute	720	Air inlet	1/2"
Free speed	4.500 rpm	Ø internal hose	13 mm
Average air consumption	243 l/min	Weight	10,3 kg

152 mm

5 mm

105 l/min

COMPACT

221 mm



920 AN1

U09200011

Roto-orbital sander (orbit 5 mm)

TECHNICAL CHARACTERISTICS

Power	0,19 Kw
Ø Pad capacity	Ø 152 mm
Orbit	5 mm
Free speed	10.000 rpm
Average air consumption	105 l/min
Recommended air pressure	6,2 bar
Sound level	78,9±3 dB(A)
Sound power	79,9±3 dB(A)
Vibrations	11,8 m/s ²
Air inlet	1/4"
Ø hose size	10 mm
Weight	0,8 kg



125 mm

750 W

12.000 Rpm



921 A4

U09210012

Angle grinders

TECHNICAL CHARACTERISTICS

Disk diameter	Ø 125 mm
Ø disk connection	Ø 24 mm
Power	0,75 Kw
Free speed	12.000 rpm
Average air consumption	120 l/min
Recommended air pressure	6,2 bar
Sound level	86±3 dB(A)
Sound power	94±3 dB(A)
Vibrations	2,5 m/s ²
Air inlet	1/4"
Weight	1,9 Kg



1/2"

136 Nm

1,2 kg

260 mm



913 PC2 1/2"

U09130017

Impact ratchet

TECHNICAL CHARACTERISTICS

Square drive	1/2"
Bolt capacity	M10
Max torque	136 Nm
Free speed	280 rpm
Average air consumption	113 l/min
Recommended air pressure	6,2 bar

TECHNICAL CHARACTERISTICS

Sound level	99±3 dB(A)
Sound power	110±3 dB(A)
Vibration	9,1 m/s ²
Air inlet	1/4"
Ø hose size	10 mm
Weight	1,2 kg

16 m cable
Ø 10 mm

939 C1

U09390004

Air hose reel 10 mm

TECHNICAL CHARACTERISTICS

Hose length	16 m
Ø internal hose	10 mm
Max pressure	15 bar
Output threaded male connector	3/8"
Dimensions (bracket included)	450x400x230 mm
Weight	8 kg



20.000 Rpm



921 B1

U09210015

Straight die grinder - 0,4 CV (300W)

TECHNICAL CHARACTERISTICS		TECHNICAL CHARACTERISTICS	
Average air consumption	113 l/min	Vibrations	2,5 m/s ²
Recommended air pressure	6,2 bar	Air inlet	1/4"
Sound level	93,3±3 dB(A)	Ø hose size	10 mm
Sound power	104,3±3 dB(A)	Weight	660 g

30.000 Rpm



922 B1

U09220001

Straight grinder - 0.3 CV (220 W)

TECHNICAL CHARACTERISTICS		TECHNICAL CHARACTERISTICS	
Average air consumption	76 l/min	Vibrations	2,42 m/s ²
Recommended air pressure	6,2 bar	Air inlet	1/4"
Sound level	84,8±3 dB(A)	Ø hose size	10 mm
Sound power	99,5±3 dB(A)	Weight	440 g

25.000 Rpm



922 B2

U09220002

Straight grinder - 0.5 CV (368 W)

TECHNICAL CHARACTERISTICS		TECHNICAL CHARACTERISTICS	
Average air consumption	113 l/min	Vibrations	1,86 m/s ²
Recommended air pressure	6,2 bar	Air inlet	1/4"
Sound level	85,4±3 dB(A)	Ø hose size	10 mm
Sound power	99,8±3 dB(A)	Weight	675 g

23.000 Rpm



922 BP1

U09220004

90° Angle grinder - 0.3 CV (220 W)

TECHNICAL CHARACTERISTICS		TECHNICAL CHARACTERISTICS	
Average air consumption	76 l/min	Vibrations	4,54 m/s ²
Recommended air pressure	6,2 bar	Air inlet	1/4"
Sound level	85,9±3 dB(A)	Ø hose size	10 mm
Sound power	96,9±3 dB(A)	Weight	555 g

28.000 Rpm



922 BL1

U09220003

Long anvil straight grinder - 0.3 CV (220 W)

TECHNICAL CHARACTERISTICS		TECHNICAL CHARACTERISTICS	
Average air consumption	76 l/min	Vibrations	2,86 m/s ²
Recommended air pressure	6,2 bar	Air inlet	1/4"
Sound level	83,3±3 dB(A)	Ø hose size	10 mm
Sound power	94,3±3 dB(A)	Weight	664 g



16
PIECES

1/2"

1/2" **5/16"**

↔ 210
↓ 60
mm ↗ 130

687 1/2" C16

U06870100



Assortment with IMPACT bits in ABS case

DESCRIPTION	ITEM/SIZE	PCS.
Impact bit-holder sockets	685 6 1/2	1
Impact bit-holder sockets	685 8 5/16	1
Impact bits for hexagonal screws - 1/2" connection	687 E 6-7-8-10-12-14	6
Impact bits for TORX® screws - 1/2" connection	687 TX T30-T40-T45-T50-T55	5
Impact bits for PHILLIPS® screws - 5/16" connection	686 PH 2-3-4	3



16
PIECES

1/2"

↔ 375
↓ 80
mm ↗ 186

235 1/2" M/C16

U02359285



Assortment with IMPACT hexagonal sockets in modular box

DESCRIPTION	ITEM/SIZE	PCS.
Impact hexagonal sockets	235 1/2 M 10-12-13-14-15-16-17-18-19-21-22-24-27-30-32 mm	15
Lock pins	235 MCA/4-6	2
Safety rings	235 MDA/4-6	2
Impact extensions	236 1/2 M/125	1



6
PIECES

3/4" **7/8"**

↔ 210
↓ 60
mm ↗ 130

688 3/4" MD6

U06880010



Assortment with IMPACT bits in ABS case

DESCRIPTION	ITEM/SIZE	PCS.
Holder for impact bits	685 B 1 7/8	1
Impact bits for hexagonal screws - 7/8" connection	688 E 12-17-19-22-24	5



8
PIECES

3/4"

↔ 375
↓ 80
mm ↗ 186

235 3/4" M/C8

U02359286



Assortment with short hexagonal impact sockets

DESCRIPTION	ITEM/SIZE	PCS.
Impact hexagonal sockets	235 3/4" M 21-22-24-27-30-32-36-41 mm	8



IMPACT SOCKETS 235 MB



1/2"
10
PIECES

→ 190
↓ 58
mm ↗ 144



1/2"

1/2"

22
PIECES

→ 415
↓ 92
mm ↗ 283

235 1/2" MB/C10 U02350530



Assortment with short hexagonal impact sockets

DESCRIPTION	ITEM/SIZE	PCS.
Short impact hexagonal sockets	235 1/2" M 10-11-12-13-14-15-16-17-18-19	10

236 KE/C22 U02360900



Assortment with short hexagonal impact sockets, extension wrench and impact bits

DESCRIPTION	ITEM/SIZE	PCS.
Short impact hexagonal sockets	235 1/2" MB 13-14-15-16-17-18-19	7
Bit-holder chain extension in Aluminium	236 KE 1/2"	1
Impact bits for hexagonal screws - 1/2" connection	687 E 5-6-8-10-12-14	6
Impact bits for TORX® screws - 1/2" connection	687 TX T25-T27-T30-T40-T45-T50-T55	7
Adapter for impact sockets	236 KEADP	1

USE WITH RATCHET OR
IMPACT WRENCH

236 K for sockets



YouTube

GREAT ACCESSIBILITY
HEAD DIMENSIONS AS A RATCHET*:



39 mm

*Comparison with 1/2" ratchet.

236 K

1/2" **1/4"**

Chain extension in Aluminium for sockets

CODE	□	L	H	📈
U02360700	1/2"	340 mm	39 mm	1,1 kg
U02360698	1/4"	260 mm	27 mm	300 g

236 KE for bits



YouTube

MINIMUM SIZE
DIRECT COUPLING FOR
IMPACT BITS.

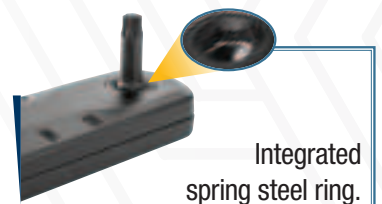

Integrated
spring steel ring.

236 KE

1/2" **1/2"** **1/4"** **1/4"**

Bit-holder chain extension in Aluminium

CODE	□	◇	L	H	📈
U02360705	1/2"	1/2"	340 mm	24 mm	1,1 kg
U02360710	1/4"	1/4"	260 mm	19 mm	300 g

THE COMPLETE CATALOG AT YOUR FINGERTIPS, ALWAYS UPDATED



Download the App!

- Works offline.
- Push notifications.
- Light.



ON SMARTPHONE AND TABLET

Do you need support from us?
Go to our website:



usag.it/en/contacts/support



Promotion valid till 31/03/2024 while stocks last.

The images shown in this catalogue are not binding.

Stanley Black & Decker italia S.r.l. reserves the right to change the technical characteristics of its products at any time.



Stanley Black & Decker Italia S.r.l.

Via Volta, 3 - 21020 - Monvalle (VA) - Tel. +39 0332 790 111 - info.mv@usag.it

usag-tools.net

